

Neostat

Room Thermostat, Room Humidistat

General

Neostat Models TY600_Z, TTY6023Z, and TY900_Z are series of electric room thermostat. Neostat Model HY6000Z is an electric room humidistat.

Neostat is similar in design and size to Neosensor, the electronic room temperature and/or humidity sensor.

A temperature-sensitive diaphragm is adopted for the thermostat, and a moisture-sensitive nylon ribbon is adopted for the humidistat.

Features

- Simple connection to an actuator allows easy temperature/humidity control.
- Compact (thin) and lightweight.
- Several installation types selectable in combination with optional auxiliary devices.



Model Numbers

Thermostat

Model number	Control action	Range	Switch for heating/cooling changeover	Our corporate logo (on the cover)
TY6000Z2000	Two-position, one-step	10 °C to 30 °C	Without switch	Printed
TY6000Z2000-1				Not printed
TY6001Z2000			With switch	Printed
TY6001Z2000-1				Not printed
TTY6023Z2000	Two-position, two-step		Without switch	Printed
TTY6023Z2000-1				Not printed
TY9000Z2000	Proportional*		Without switch	Printed
TY9000Z2000-1				Not printed
TY9001Z2000			With switch	Printed
TY9001Z2000-1				Not printed

Note:

* Use Neostat (proportional type) with our Control Motor, ACTIVAL™, etc.

Humidistat

Model number	Control action	Range	Our corporate logo (on the cover)
HY6000Z2000	Two-position	30 %RH to 90 %RH	Printed
HY6000Z2000-1			Not printed



Safety Instructions

Please read instructions carefully and use the product as specified in this manual. Be sure to keep this manual near by for ready reference.







Usage Restrictions









This product is targeted for general air conditioning. Do not use this product in a situation where human life may be affected. If this product is used in a clean room or a place where reliability or control accuracy is particularly required, please contact our sales representative. Azbil Corporation will not bear any responsibility for the results produced by the operators.

Warnings and Cautions

	WARNING	Alerts users that improper handling may cause death or serious injury.
	CAUTION	Alerts users that improper handling may cause minor injury or material loss.

Signs

	Alerts users possible hazardous conditions caused by erroneous operation or erroneous use. The symbol inside  graphically indicates the specific type of danger. (For example, the sign on the left warns of the risk of electric shock.)
	Notifies users that specific actions are prohibited to prevent possible danger. The symbol inside  graphically indicates the prohibited action. (For example, the sign on the left notifies that disassembly is prohibited.)
	Instructs users to carry out a specific obligatory action to prevent possible danger. The symbol inside  graphically indicates the actual action to be carried out. (For example, the sign on the left indicates general instructions.)

 CAUTION	
	Use the product under the operating conditions (temperature, humidity, power, vibration, shock, mounting direction, atmospheric condition, etc.) as listed in the specifications. Failure to do so might cause fire or device failure.
	Use the product within the rated operating ranges as listed in the specifications. Failure to do so might cause device failure.
	Installation and wiring must be performed by qualified personnel in accordance with all applicable safety standards.
	All wiring must comply with applicable codes and ordinances.
	Before wiring, be sure to turn off the power to the product. Failure to do so might cause electric shock.
	To connect the wires to the screw terminals, use crimp terminal lugs with insulation. Failure to do so might cause fire or device failure due to short circuit.
	Do not disassemble the product. Doing so might cause electric shock or device failure.
	Dispose of the product as industrial waste in accordance with your local regulations. Do not reuse all or part of this product.

Part Numbers of Optional Items

Mount Neostat with the following optional items (sold separately). Order necessary items.

Item		Part number/Model number	Note
Adapter		Part No. 83172617-001	—
Auxiliary device	Thermoplate for individual room control	Model QY1100A	With slide switch
		Model QY1100C	With rotary switch
		Model QY1100D	
	Thermoplate	Part No. DY2000A1022	For mounting one Neostat, lengthwise
		Part No. DY2000A1023	For mounting one Neostat, crosswise
		Part No. DY2000A2023	For mounting two Neostat in 94mm (H) x 192mm (W) outlet box, crosswise
		Part No. DY2000A2024	For mounting two Neostat in 106mm (H) x 198mm (W) outlet box, crosswise
		Part No. DY2000A3022	For mounting three Neostat, crosswise
	Thermoplate for open wiring * Thermoplate for open wiring is used for open wiring installation.	Part No. DY2000A1021	For mounting one Neostat, square
		Part No. DY2000A2021	For mounting two Neostat, crosswise
Part No. DY2000A3021		For mounting three Neostat, crosswise	
Multi-Thermocase		Model TY1100Z	—

Specifications

Item		Specification		
Differential (of two-position control)		Models TY600_Z, TTY6023Z: 1.5 ± 1 °C (at 10 °C to 30 °C)		
Temperature difference between steps (of two-position, two-step control)		Model HY6000Z: 5 ± 3 %RH (at 30 %RH to 90 %RH)		
Proportional band (of proportional control)		Model TY900_Z: 2 ± 1 °C fixed (at 10 °C to 30 °C)		
Sensing elements	Thermostat	Temperature-sensitive diaphragm		
	Humidistat	Moisture-sensitive nylon ribbon		
Environmental conditions		Rated operating conditions	Transport/storage conditions	
Thermostat	Ambient temperature	0 °C to 50 °C	-20 °C to 50 °C	
	Ambient humidity	10 %RH to 90 %RH (non-condensing)	5 %RH to 95 %RH (non-condensing)	
Humidistat	Ambient temperature	10 °C to 40 °C	-20 °C to 50 °C	
	Ambient humidity	10 %RH to 90 %RH (non-condensing)	5 %RH to 95 %RH (non-condensing)	
Contact rating of two-position control ^{*1,*2}		125 V AC	250 V AC	
Thermostat	Current in operation	Model TY600_Z: 6 A	Model TY600_Z: 3 A	
		Model TTY6023Z: 4A	Model TTY6023Z: 2A	
	Current at startup	Model TY600_Z: 24 A	Model TY600_Z: 12 A	
		Model TTY6023Z: 16A	Model TTY6023Z: 8 A	
	Humidistat ^{*3}	Current in operation	3 A for dehumidifying/humidifying	1.5 A for dehumidifying/humidifying
		Current at startup	12 A for dehumidifying/humidifying	6 A for dehumidifying/humidifying
Resistive load		4.5 A for dehumidifying/humidifying	2 A for dehumidifying/humidifying	
Color		Pale gray		
Materials	Cover	PC resin		
	Base	PC resin		
Weight		Approx. 180 g		
Installation		With the mounting kit (sold separately)		
Connection		Models TY600_Z, TY900_Z, HY6000Z: Screw terminal connection Model TTY6023Z: Lead wire connection		
Accessory		Two mounting screws (M4 x 10 pan-head machine screws)		

Notes:

*1 Minimum allowable current is 50 mA.

*2 Select a device (load) of which the Neostat contact rating is tolerable. If a load larger than the Neostat contact rating is connected to Neostat, the contact may be welded and may not turn on or off.

*3 Contact rating of the humidistat model (Model HY6000Z) shown above is the maximum current at startup and in operation when Model HY6000Z is connected to dehumidifier/humidifier.

Dimensions

Neostat

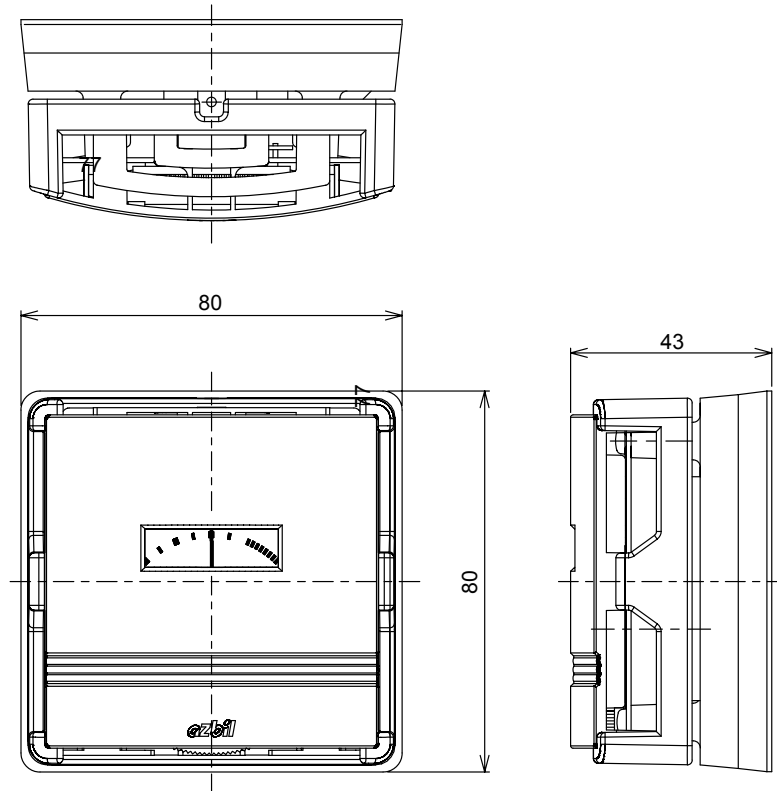

Note:

* Secure more than 15 mm clearance inside the mounting wall when installing Neostat.

Figure 1. Dimensions (mm): Neostat

Adapter

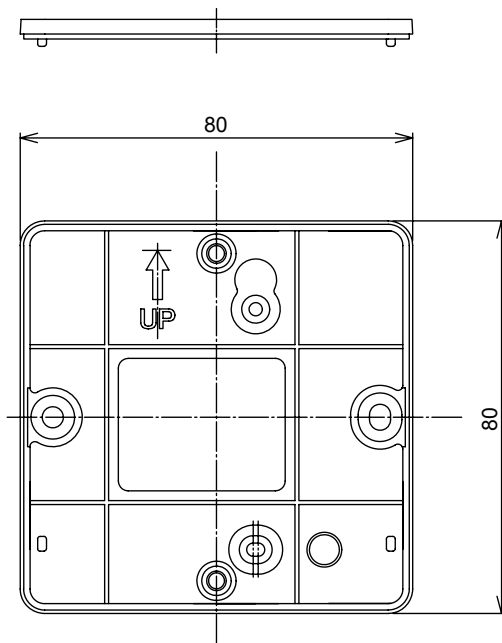

Figure 2. Dimensions (mm): Adapter

Installation

CAUTION



Use the product under the operating conditions (temperature, humidity, power, vibration, shock, mounting direction, atmospheric condition, etc.) as listed in the specifications.
Failure to do so might cause fire or device failure.



Installation and wiring must be performed by qualified personnel in accordance with all applicable safety standards.

Requirements for installation location

IMPORTANT:

- Installation location of Neostat largely affects temperature or humidity control. Carefully select the location.
- Ask our salesperson for use of Neostat in a special application, as mentioned below.
 - Chemical (organic solvent) atmosphere may shift the output values.
 - Corrosive gas, organic solvent, and other chemicals contained in the atmosphere can cause measuring error of Neostat, shorten the service life of Neostat, or damage Neostat.
- Do not tighten or loosen the screws (except the screws described in the **Installation steps** sections). Doing so might damage Neostat.
- Hold the guide, but not the setting dial, when lifting the Neostat main unit. (See Fig. 3)
Failure to do so might damage Neostat.

Install Neostat on an indoor wall where:

- Representative temperature/humidity (of the room/zone to control) can be measured (approx. 1.5 m high above the floor).
- Ambient wind velocity is 0.1 to 0.15 m/s.
- There is enough maintenance space left in front of Neostat.

Do not install Neostat on a wall where:

- Heat (generated by office device or equipment, for example) stays on.
- Air circulation is interfered (by furniture or door, for example).
- Humidity/temperature sensing is affected by draft, downdraft, and hot/cold air from water pipes/ducts.
- Humidity/temperature sensing is affected by weather conditions (including sunlight and outdoor air).
- There is vibration.
- Dew condensation occurs.
- Water drops on.
- Hot/chilled water pipe or steam pipe is located within 1 m radius.
- Atmosphere that contains corrosive gas, organic solvent, or other chemicals surrounds.
- Polluted environment that contains oil mist or other contaminants surrounds.
- Dust gathers on Neostat. (This may cause current leakage.)

Do not install Neostat outdoors or in a duct.

Do not install Neostat directly or horizontally on a ceiling.

Precautions for installation

- Secure the clearance for wiring inside the wall (as shown in Figs. 1 and 3).
- Install Neostat with a dedicated mounting kit (sold separately) suitable for your application.
- Do not allow any refuse such as an electric wire scrap to get inside Neostat.
- Do not allow the lead wires caught between the mounting surface of Neostat and the wall.
- Do not put heavy load on the setting dial, the lead wires, etc. Doing so may distort Neostat, causing failure or affecting humidity control.
- If air infiltrates to the rear side of the Neostat from the inside of the installed wall through the outlet box, shut off the air by sealing the outlet box.
- Be sure to tighten all the screws necessary for installation.
- Tighten the screws with the specified torque (78.5 N-cm for terminals and wall mounting screws, 39.2 N-cm for main unit mounting screws). Neostat may get damaged by excessive tightening and may drop from the wall by insufficient tightening.
- Be careful not to touch the diaphragm or nylon ribbon when Neostat is uncovered.
- After installation, leave Neostat well so that it adapts to ambient conditions (atmospheric environment).

Cover removal

To remove the cover:

Press the spring, located on the upper center part of the Neostat main unit, using a thin object.

To attach the cover:

Engage the tabs, located on the lower part of the cover, with the slots on the lower part of the main unit. Then fix the cover with the spring, located on the upper center part of the Neostat main unit.

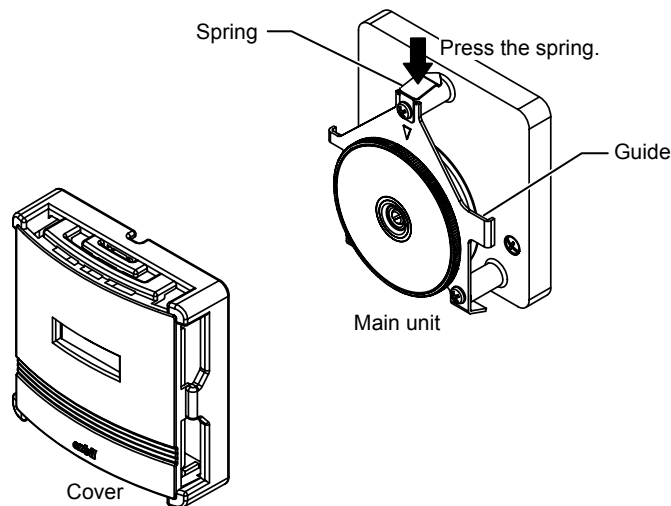

Figure 3. Cover removal

Installation steps: Neostat directly on a wall (for new installation)

- 1) Mount the outlet box cover (conforming to JIS C8340:1999 Boxes and box covers for rigid metal conduits (mounting dimension: 66.7 mm)) so that the two mounting holes are vertically aligned.
- 2) Remove the cover from Neostat. (See the **Cover removal** section.)
- 3) Unscrew the Neostat main unit screw. Then, hold and lift the guide to remove the main unit from the base. Do not hold the setting dial to remove the main unit.
- 4) Attach the Neostat base to the outlet box cover so that the arrow (indicated with "UP") points upwards, using two pan-head machine screws (M4 x 10) supplied with Neostat. (Tightening torque: 78.5 N·cm)
- 5) Wire Neostat. (See the **Wiring** section.)
- 6) Attach the Neostat main unit to the base, using the main unit screw (M3) preassembled with the Neostat main unit. (Tightening torque: 39.2 N·cm)
- 7) Attach the Neostat cover to the main unit. (See the **Cover removal** section.)

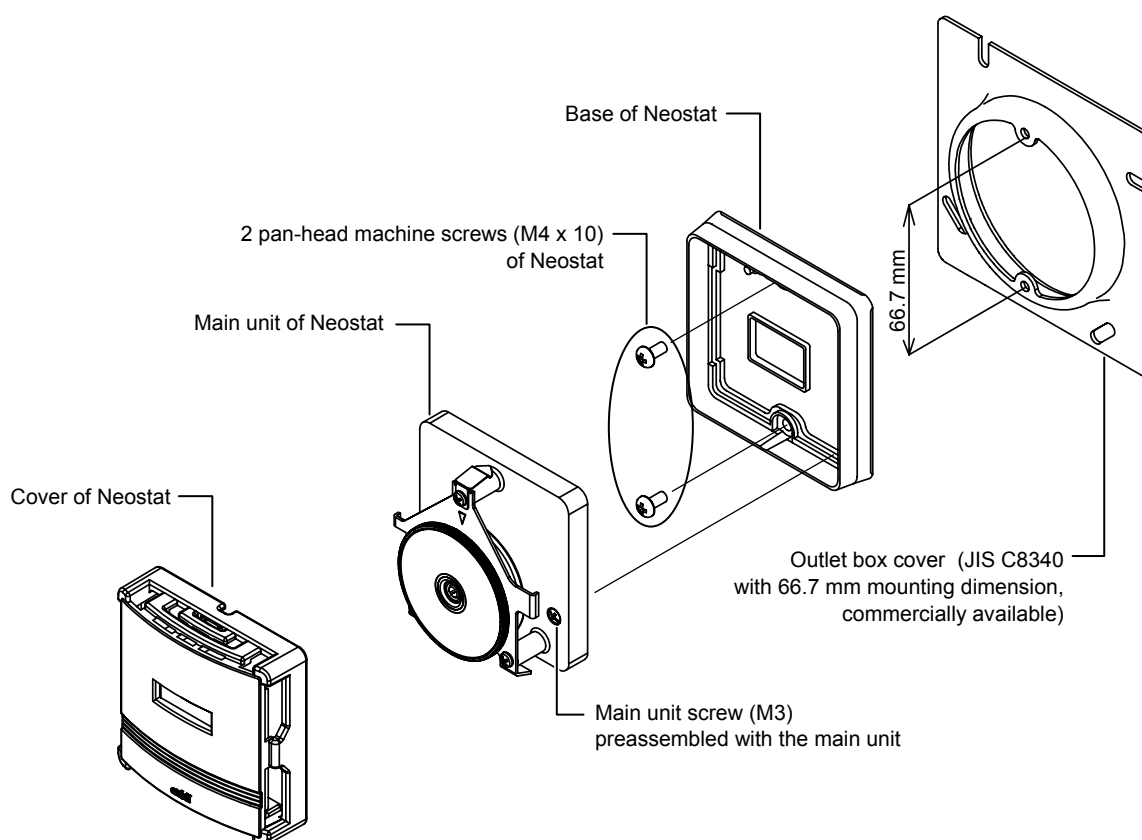

Figure 4. Installation: Neostat directly on a wall (for new installation)

Installation steps: Neostat directly on a wall with the adapter (for replacement of the former model)

Outlet box cover (conforming to JIS C8340:1999 Boxes and box covers for rigid metal conduits (mounting dimension: 66.7 mm)) of the former model Neostat is mounted with the two mounting holes horizontally aligned. Provide the adapter (Part No. 83172617-001) to replace with the new model Neostat.

- 1) Remove the cover from Neostat. (See the **Cover removal** section.)
- 2) Unscrew the Neostat main unit screw. Then, hold and lift the guide to remove the main unit from the base. Do not hold the setting dial to remove the main unit.
- 3) Attach the adapter to the outlet box cover so that the arrow (indicated with "UP") points upwards, using two flat-head screws (M4 x 10) supplied with the adapter. (Tightening torque: 78.5 N·cm)
- 4) Attach the Neostat base to the adapter so that the arrow (indicated with "UP") points upwards, using two pan-head machine screws (M4 x 6) supplied with the adapter. (Tightening torque: 78.5 N·cm)
Note: Do not use pan-head machine screw (M4 x 10) supplied with Neostat.
- 5) Wire Neostat. (See the **Wiring** section.)
- 6) Attach the Neostat main unit to the base, using the main unit screw (M3) preassembled with the Neostat main unit. (Tightening torque: 39.2 N cm)
- 7) Attach the Neostat cover to the main unit. (See the **Cover removal** section.)

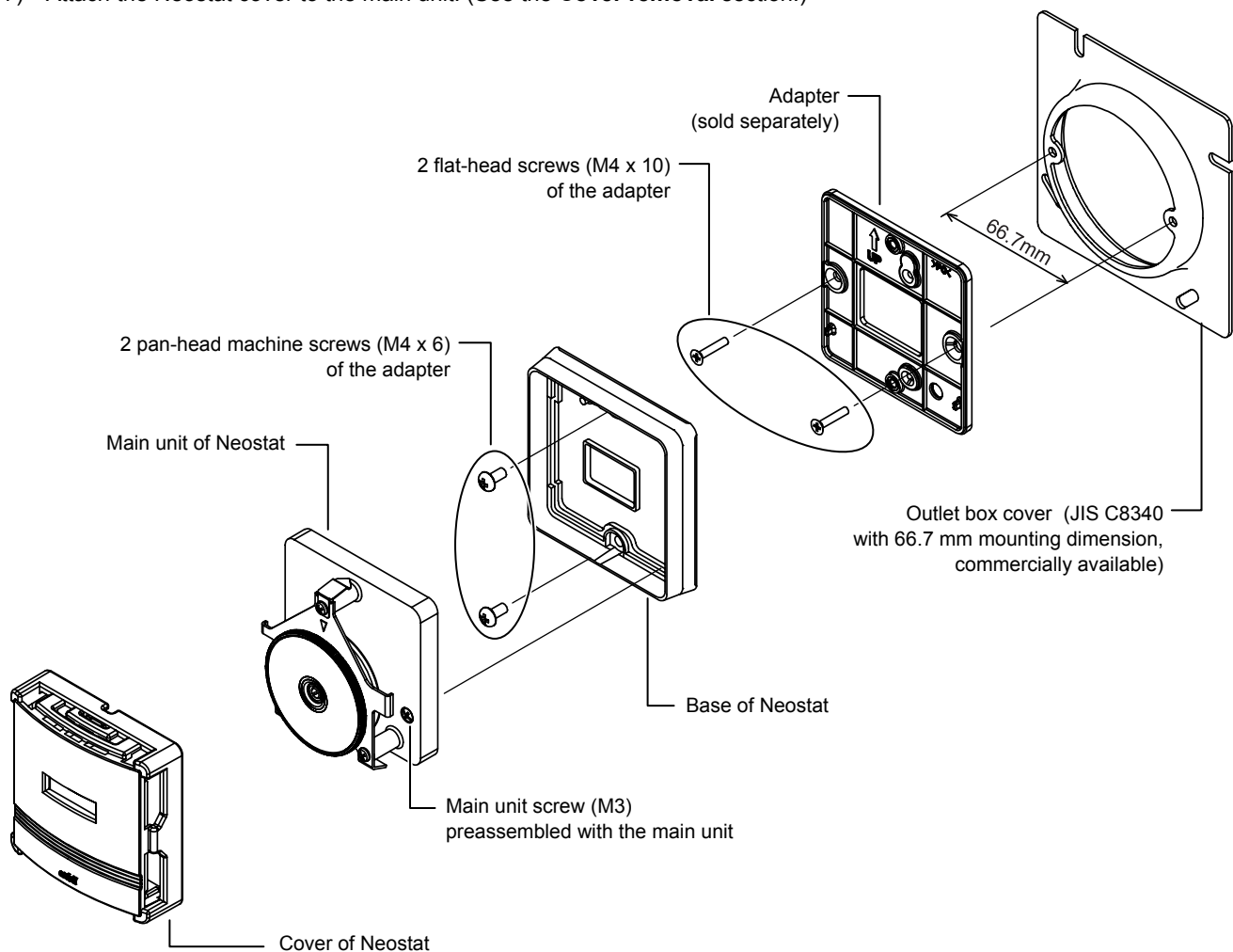

Figure 5. Installation: Neostat directly on a wall (for replacement of the former model)

Installation steps: Neostat on Thermoplate for open wiring with the adapter

- 1) Remove the cover from Neostat. (See the **Cover removal** section.)
- 2) Unscrew the Neostat main unit screw. Then, hold and lift the guide to remove the main unit from the base. Do not hold the setting dial to remove the main unit.
- 3) Attach the adapter to the Thermoplate for open wiring so that the arrow (indicated with "UP") points upwards, using two flat-head screws (M4 x 10) supplied with the adapter. (Tightening torque: 78.5 N·cm)
- 4) Attach the Neostat base to the adapter so that the arrow (indicated with "UP") points upwards, using two pan-head machine screws (M4 x 6) supplied with the adapter. (Tightening torque: 78.5 N·cm)
Note: Do not use pan-head machine screw (M4 x 10) supplied with Neostat.
- 5) Wire Neostat. (See the **Wiring** section.)
- 6) Attach the Neostat main unit to the base, using the main unit screw (M3) preassembled with the Neostat main unit. (Tightening torque: 39.2 N·cm)
- 7) Attach the Neostat cover to the main unit. (See the **Cover removal** section.)

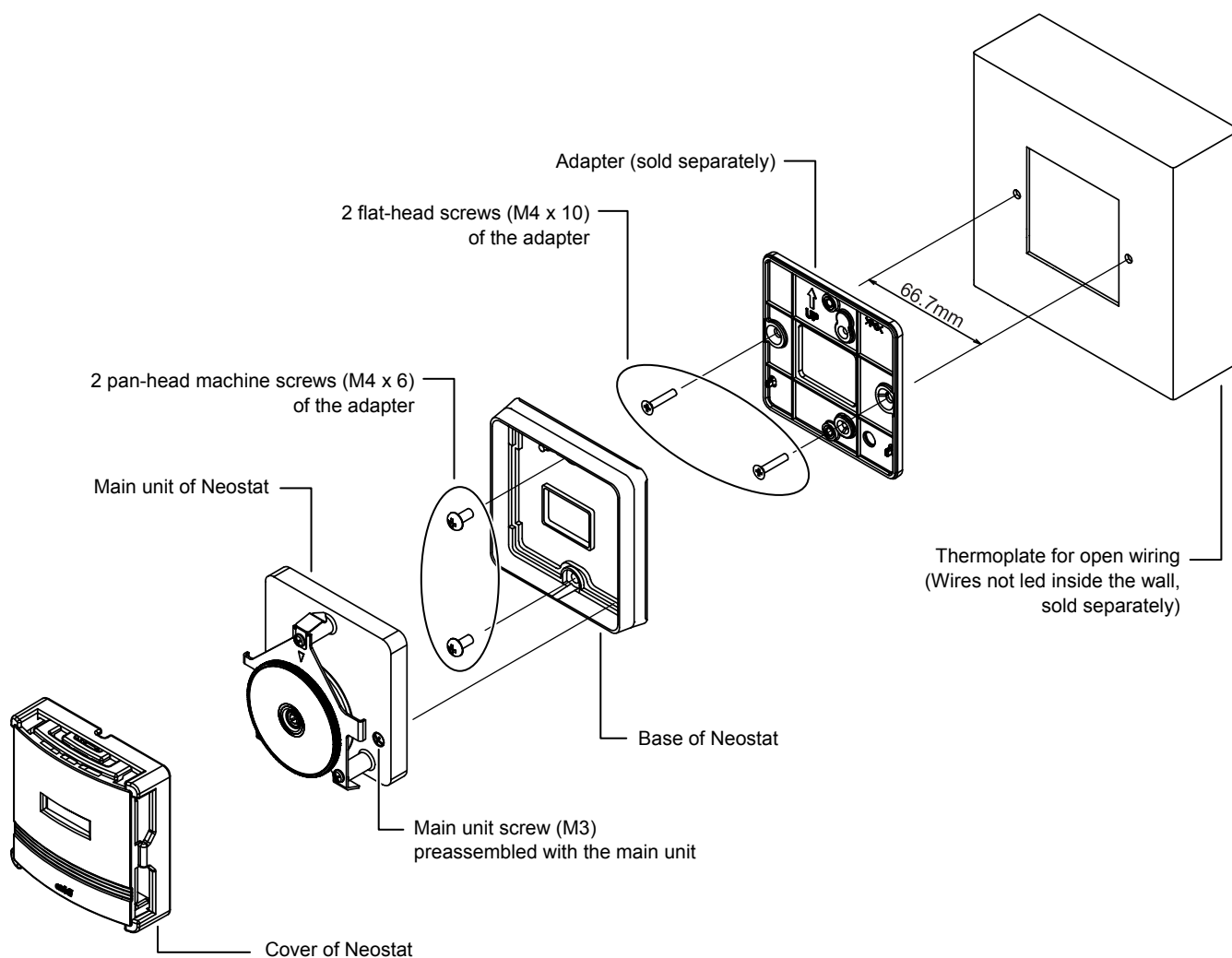
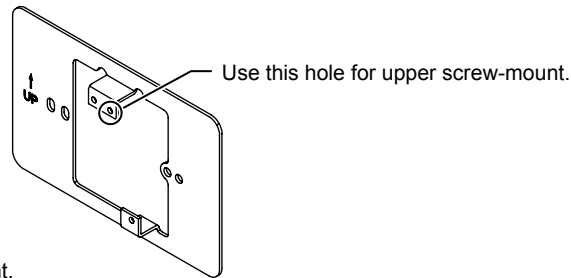

Figure 6. Installation: Neostat on Thermoplate for open wiring

Installation steps: Neostat on Thermoplate with the adapter

- 1) Attach the mounting plate of Thermoplate to the outlet box cover (JIS C8340:1999 Boxes and box covers for rigid metal conduits (mounting dimension: 83.5 mm)) on the mounting surface with two pan-head machine screws (M4 x 8) supplied with Thermoplate.
- 2) Attach the main unit of Thermoplate to its mounting plate with two pan-head machine screws (M3 x 5) supplied with Thermoplate.



Note: Do not use the other hole for upper screw-mount.

Figure 7. Mounting plate of Thermoplate

- 3) Attach the adapter to Thermplate so that the arrow (indicated with "UP") points upwards, using two flat-head tapping screws (M2.6 x 8) supplied with Thermoplate.
- 4) Remove the cover from Neostat. (See the **Cover removal** section.)
- 5) Unscrew the Neostat main unit screw. Then, hold and lift the guide to remove the main unit from the base. Do not hold the setting dial to remove the main unit.
- 6) Attach the Neostat base to the adapter so that the arrow (indicated with "UP") points upwards, using two pan-head machine screws (M4 x 6) supplied with the adapter. (Tightening torque: 78.5 N-cm)
Note: Do not use pan-heat machine screw (M4 x 10) supplied with Neostat.
- 7) Wire Neostat. (See the **Wiring** section.)
- 8) Attach the Neostat main unit to the base, using the main unit screw (M3) preassembled with the Neostat main unit. (Tightening torque: 39.2 N cm)
- 9) Attach the Neostat cover to the main unit. (See the **Cover removal** section.)

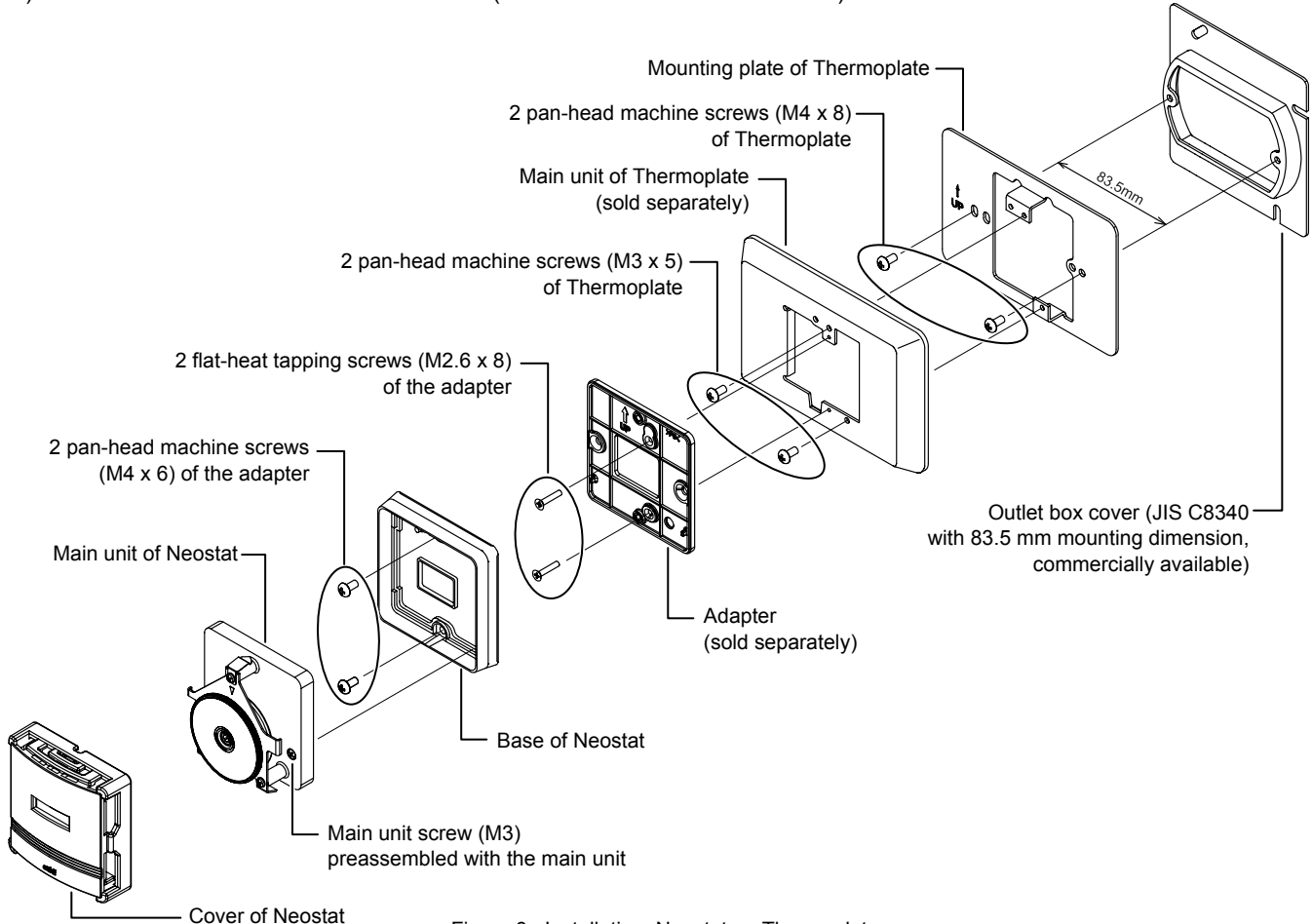

Figure 8. Installation: Neostat on Thermoplate

Installation steps: Neostat in Multi-Thermocase with the adapter

Mount Neostat onto one of the mounting windows with 66.7 mm mounting dimension of the device mounting plate (included in Multi-Thermocase).

- 1) Attach the adapter to the device mounting plate of Multi-Thermocase using two pan-head machine screws (M3 x 6) supplied with Multi-Thermocase.
- 2) Remove the cover from Neostat. (See the **Cover removal** section.)
- 3) Unscrew the Neostat main unit screw. Then, hold and lift the guide to remove the main unit from the base. Do not hold the setting dial to remove the main unit.
- 4) Attach the Neostat base to the adapter so that the arrow (indicated with "UP") points upwards, using two pan-head machine screws (M4 x 6) supplied with the adapter. (Tightening torque: 78.5 N·cm)
Note: Do not use pan-head machine screw (M4 x 10) supplied with Neostat.
- 5) Wire Neostat. (See the **Wiring** section.)
- 6) Attach the Neostat main unit to the base, using the main unit screw (M3) preassembled with the Neostat main unit. (Tightening torque: 39.2 N·cm)
- 7) Attach the cover of Multi-Thermocase.
Note: In Multi-Thermocase, Neostat is installed with its cover removed.

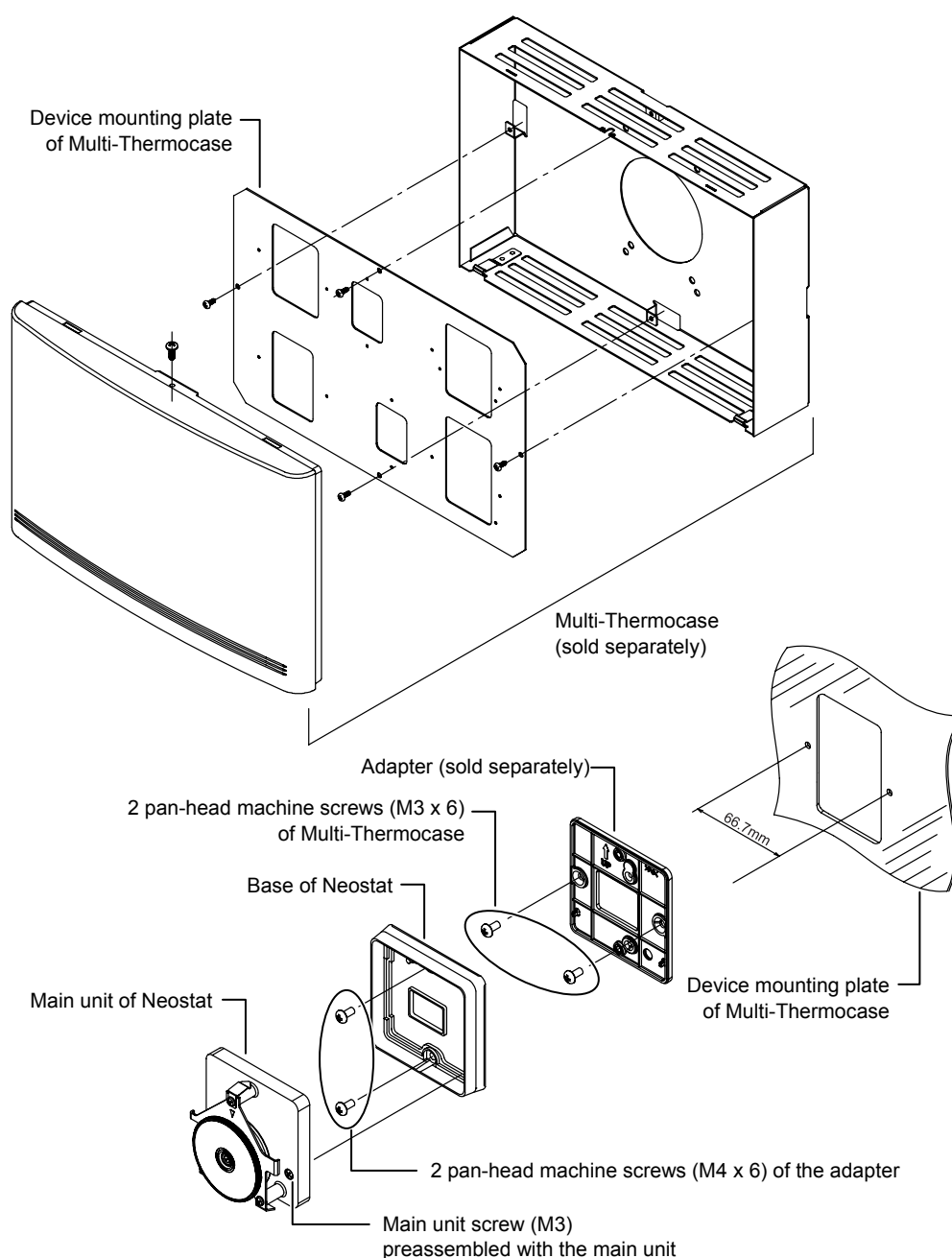

Figure 9. Installation: Neostat in Multi-Thermocase

Wiring

CAUTION	
	Installation and wiring must be performed by qualified personnel in accordance with all applicable safety standards.
	All wiring must comply with applicable codes and ordinances.
	Before wiring, be sure to turn off the power to the product. Failure to do so might cause electric shock.
	To connect the wires to the screw terminals, use crimp terminal lugs with insulation. Failure to do so might cause fire or device failure due to short circuit.

Model TTY6023Z2000 adopts lead wire connection and the rest of the models adopt terminal connection.

Precautions for wiring

- Use M4 crimp terminals to connect wires to the Neostat screw terminals. (Tightening torque: 78.5 N·cm)
- For connecting wires from the load, use 1.25 mm² or greater stranded annealed copper wires with insulation.
- For splicing lead wires (from the load and from Neostat), use crimp sleeves with insulation.
- Correctly connect the wires from the load to Neostat.
- Make sure that all the wires are tightly connected.

Wiring diagram

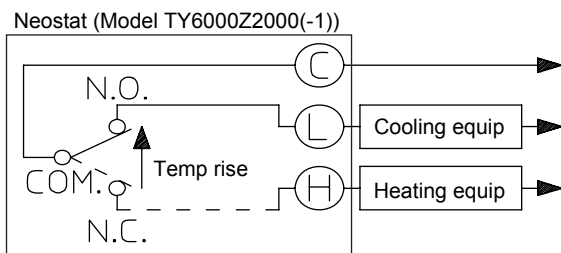

Figure 10. Wiring diagram: Model TY6000Z2000(-1)

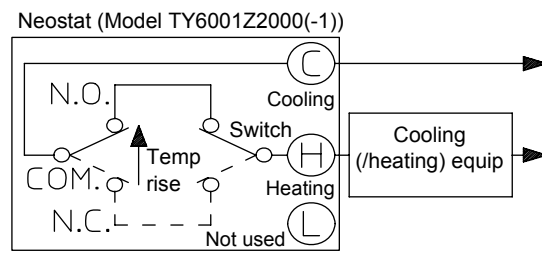
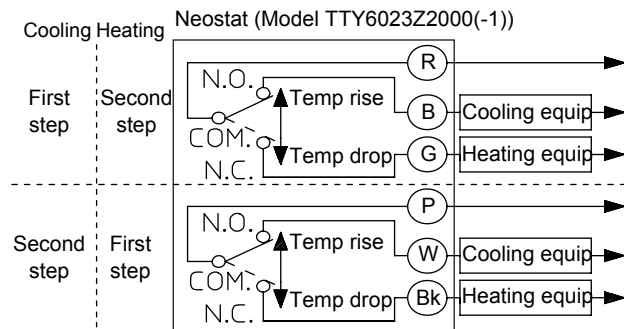

Figure 11. Wiring diagram: Model TY6001Z2000(-1)



Lead wire color
R: Red, B: Blue, G: Gray P: Pink, W: White, Bk: Black

Figure 12. Wiring diagram: Model TTY6023Z2000(-1)

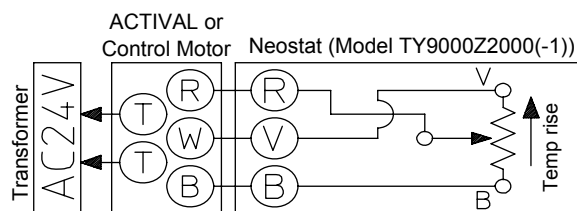

Figure 13. Wiring diagram: Model TY9000Z2000(-1)

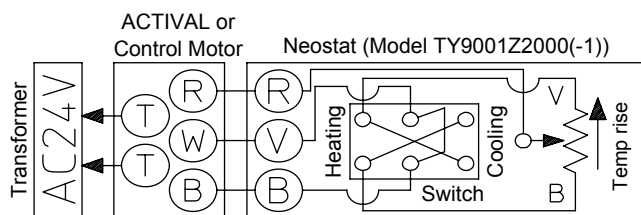

Figure 14. Wiring diagram: Model TY9001Z2000(-1)

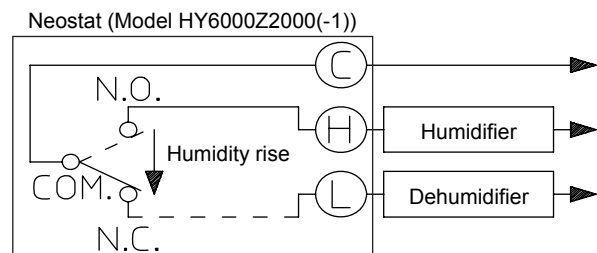

Figure 15. Wiring diagram: Model HY6000Z2000(-1)

Wiring to the load

IMPORTANT:
 Select a device (load) of which the Neostat (two-position type) contact rating is tolerable. If a load larger than the Neostat contact rating is connected to Neostat, the contact may be welded and may not turn on or off.

Wiring of the thermostat model

- Model TY600_Z is the two-position one-step type thermostat for ON/OFF control of a electric motor, electric heater, solenoid valve, auxiliary relay, or the like.
 - Model TTY6023Z is the two-position two-step type thermostat for dual-step ON/OFF control of a packaged air conditioner, electric motor, electric heater, or the like.
 - Model TY900_Z is the proportional type thermostat for proportional control of the Control Motor (Model MY3000) or ACTIVAL (Model VY512_/ MY532_) that actuates valve or damper
- Note: Modutrol Motor cannot be connected to Neostat.

IMPORTANT:
 To connect Model TY900_Z to a device other than the above mentioned, ask our salesperson to check if Model TY900_Z is connectable to the device.

Wiring of the humidistat model

- Model HY6000Z is the two-position one-step type humidistat for ON/OFF control of a solenoid valve, auxiliary relay, or the like.

Switching Action of Two-position Control

Thermostat (two-position one-step type) Model TY600_Z2000(-1)

Model number	Mode	Contact between:		Switch for heating/cooling changeover
		Terminals L and C	Terminals H and C	
TY6000Z2000(-1)	Cooling	Closed	Open	N/A
	Heating	Open	Closed	N/A
TY6001Z2000(-1)	Cooling	N/A	Closed	Cooling
	Heating	N/A	Open	Heating

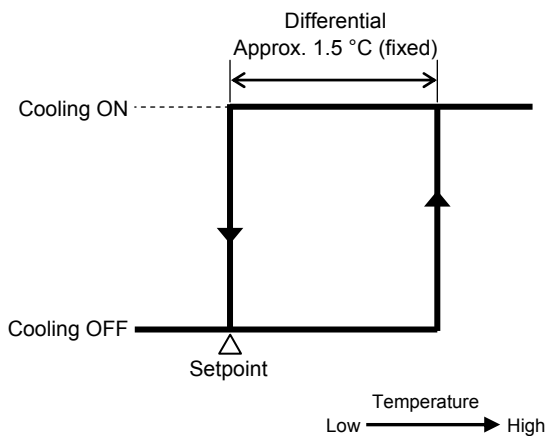

Figure 16. Switching action of Model TY600_Z2000(-1) in cooling mode

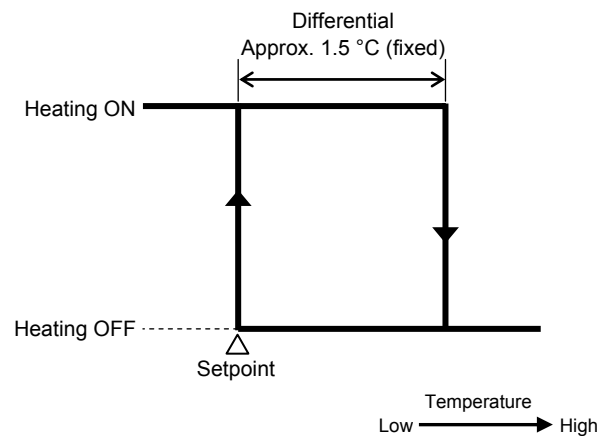

Figure 17. Switching action of Model TY600_Z2000(-1) in heating mode

Thermostat (two-position one-step type) Model TTY6023Z2000

Model number	Mode	Contact between:			
		Blue and red wires	Gray and red wires	White and pink wires	Black and pink wires
TTY6023Z2000(-1)	Cooling (step 1)	Closed	Open	N/A	N/A
	Cooling (step 2)	Closed	Open	Closed	Open
	Heating (step 1)	N/A	N/A	Open	Closed
	Heating (step 2)	Open	Closed	Open	Closed

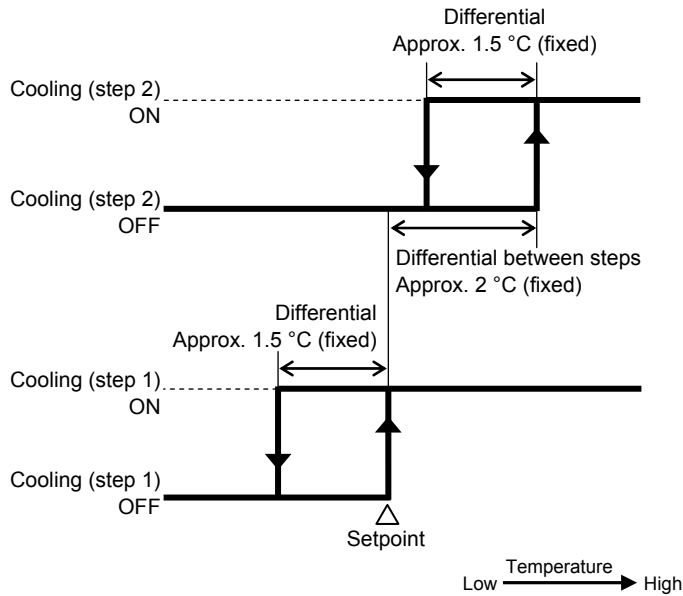

Figure 18. Switching action of Model TTY6023Z2000(-1) in cooling mode

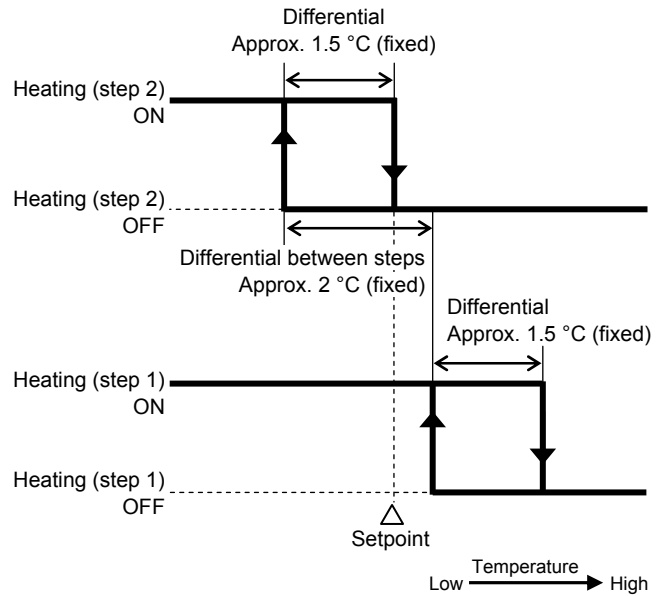

Figure 19. Switching action of Model TTY6023Z2000(-1) in heating mode

Humidistat (two-position one-step type) Model HY6000Z2000(-1)

Model number	Mode	Contact between:	
		Terminals L and C	Terminals H and C
HY6000Z2000(-1)	Humidifying	Open	Closed
	Dehumidifying	Closed	Open

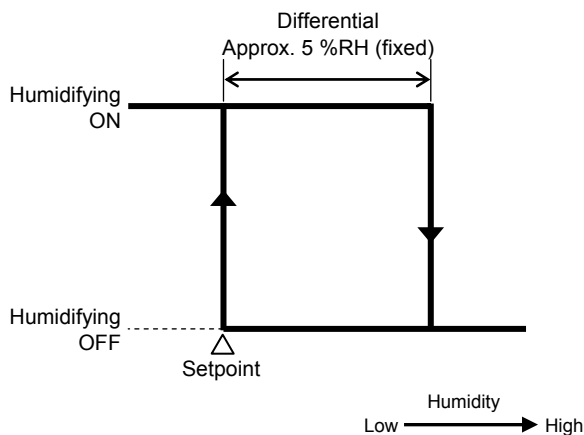

Figure 20. Switching action of Model HY6000Z2000(-1) in humidifying mode

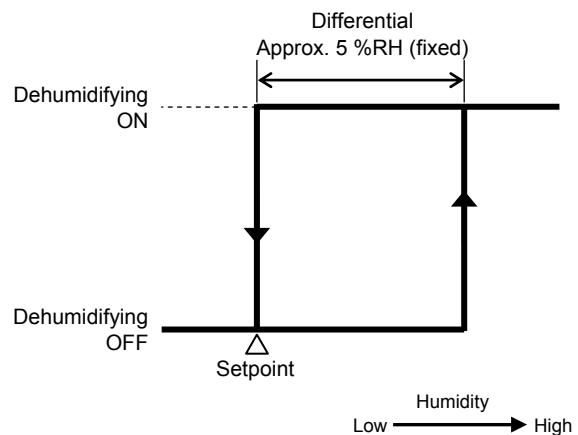

Figure 21. Switching action of Model HY6000Z2000(-1) in dehumidifying mode

Setting

Thermostat model

Heating/cooling changeover (of Models TY6001Z, TY9001Z)

- 1) Remove the cover of Neostat. (See the **Cover removal** section.)
- 2) Set the switch for heating/cooling changeover (to "HEAT" or " COOL" position).
 Note: Do not change the switch while Neostat and connected equipment are being in operation.

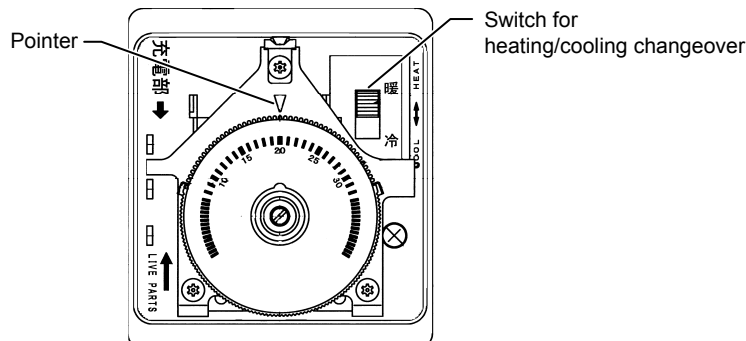

Figure 22. Switch for heating/cooling changeover of Models TY6001Z and TY9001Z

- 3) Attach the cover to the main unit.

High and low limits of the range

Adjust the high and low limits of the setting range using the range adjusters.

- 1) Remove the cover of Neostat. (See the **Cover removal** section.)
- 2) Press lightly (to release lock) and sift the range adjusters for high and low limits to the desired positions to set.



Figure 23. Change of the setting range of the thermostat model

- 3) Attach the cover to the main unit.

Lock of the setting

Lock the setpoint using the range adjusters.

- 1) Remove the cover of Neostat. (See the **Cover removal** section.)
- 2) Shift the setting dial so that the pointer points to the desired position.
- 3) Press lightly (to release lock) the range adjusters and shift the range adjusters to the top.

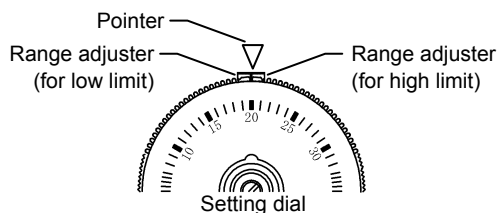

Figure 24. Lock of the setting of the thermostat model

- 4) Attach the cover to the main unit.

Humidistat model

Setpoint is factory-set and locked at 90 %RH.

Lock of the setting

- 1) Remove the cover of Neostat. (See the **Cover removal** section.)
- 2) Loosen the setting screw that fixes the setpoint.
- 3) Turn the setting dial so that the pointer points to the desired setpoint. Then, tighten the setting screw.

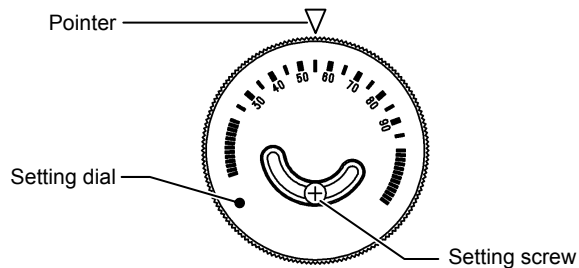

Figure 25. Lock of the setting of the humidistat model

- 4) Attach the cover to the main unit.

ACTIVAL is a trademark of Azbil Corporation in Japan or in other countries.

azbil

Specifications are subject to change without notice.

Azbil Corporation
Building Systems Company

<http://www.azbil.com/>