

# PARAMATRIX™ 4

## Chiller Controller

### General

PARAMATRIX™ 4 (often shortened to PMX-4) is a Direct Digital Controller (DDC) specifically designed only for sequential control of heating/cooling units of building HVAC (heating, ventilation, air-conditioning) systems.

The PARAMATRIX 4 Chiller Controller performs energy conservation control including the optimization of multiple chillers in response to the air conditioning load.



Through the optional PARAMATRIX 4 operator interface (OI), you can check operating status of chillers. By communicating with our building management system (BMS), the PARAMATRIX 4 Chiller Controller offers efficient chiller operation management using client PC of the BMS.

### Features

- **Safe and optimized chiller control:**  
In response to the air conditioning load at startup and during operation, PARAMATRIX 4 Chiller Controller calculates and operates the optimum number of chillers. Even if a chiller fails, the PARAMATRIX 4 will automatically operate another chiller instead of the faulty chiller if necessary. (The PARAMATRIX 4 decides if another (alternate) chiller needs to operate in response to the air conditioning load.)  
The PARAMATRIX 4 also controls chillers for power failure and for power failure restoration. Thus the PARAMATRIX 4 offers various controls of the chillers.
- **Easy operation check with optional OI:**  
The optional operator interface (OI) adopts touch panel and color LCD, and thus operability and visibility has widely been improved. A variety of display functions show its operators how the PARAMATRIX 4 has controlled/is controlling/is going to control the chillers and facilitate complex heating/cooling system management and control.
- **Compact controller:**  
Small body requires little room in a control panel.
- **Simple wiring and installation:**  
Screwless push-in terminals facilitate wiring work. PARAMATRIX 4 is mounted either with screws or on DIN rail.
- **Integral or standalone management**  
PARAMATRIX 4 serves as a standalone controller as well as a controller integrated into our BMS. Besides, PARAMATRIX 4 in combination with PARACONDUCTOR™ enables to visualize operating status and results of energy saving.  
PARAMATRIX 4 thus is suitable for standalone control and for various integrated control.
- **CE Marking certified product:**  
Model WY5130Q conforms to all the applicable standards of CE Marking.

**Safety Instructions**

Please read instructions carefully and use the product as specified in this manual. Be sure to keep this manual near by for ready reference.



**Usage Restrictions**

This product is targeted for general air conditioning. Do not use this product in a situation where human life may be affected. If this product is used in a clean room or a place where reliability or control accuracy is particularly required, please contact our sales representative. Azbil Corporation will not bear any responsibility for the results produced by the operators.



**Caution for instrumentation design**



Considering unexpected failures and contingencies, be sure to design and check safety of the system and equipments.







**Warnings and Cautions**

	<b>WARNING</b>	Alerts users that improper handling may cause death or serious injury.
	<b>CAUTION</b>	Alerts users that improper handling may cause minor injury or material loss.

**Signs**

	Alerts users possible hazardous conditions caused by erroneous operation or erroneous use. The symbol inside $\triangle$ indicates the specific type of danger. (For example, the sign on the left warns of the risk of electric shock.)
	Notifies users that specific actions are prohibited to prevent possible danger. The symbol inside $\otimes$ graphically indicates the prohibited action. (For example, the sign on the left notifies that disassembly is prohibited.)
	Instructs users to carry out a specific obligatory action to prevent possible danger. The symbol inside $\bullet$ graphically indicates the actual action to be carried out. (For example, the sign on the left indicates general instructions.)

 <b>WARNING</b>	
	Before wiring, be sure to turn off the power to the product. Failure to do so might cause electric shock.
	Install this product in a location out of reach of unauthorized people. (e.g. Inside of the control panel) Failure to do so might cause electric shock.

 <b>CAUTION</b>	
	Use the product under the operating conditions (temperature, humidity, power, vibration, shock, mounting direction, atmospheric condition, etc.) as listed in the specifications. Failure to do so might cause fire or device failure.
	Use the product within the rated operating ranges as listed in the specifications. Failure to do so might cause device failure.
	Installation and wiring must be performed by qualified personnel in accordance with all applicable safety standards.
	Do not disassemble the product. Doing so might cause device failure.
	Dispose of the product as industrial waste in accordance with your local regulations. Do not reuse all or part of this product.

**System Configurations**

**PARAMATRIX™ 4 with our BMS**

The following shows the PARAMATRIX 4 integrated into our BMS such as savic-net™ FX. PARAMATRIX 4 is connectable to System Core Server (of savic-net FX) and to PARACONDUCTOR sub-system. For connecting the PARACONDUCTOR sub-system to our BMS, refer to the specification data and manuals related to PARACONDUCTOR.

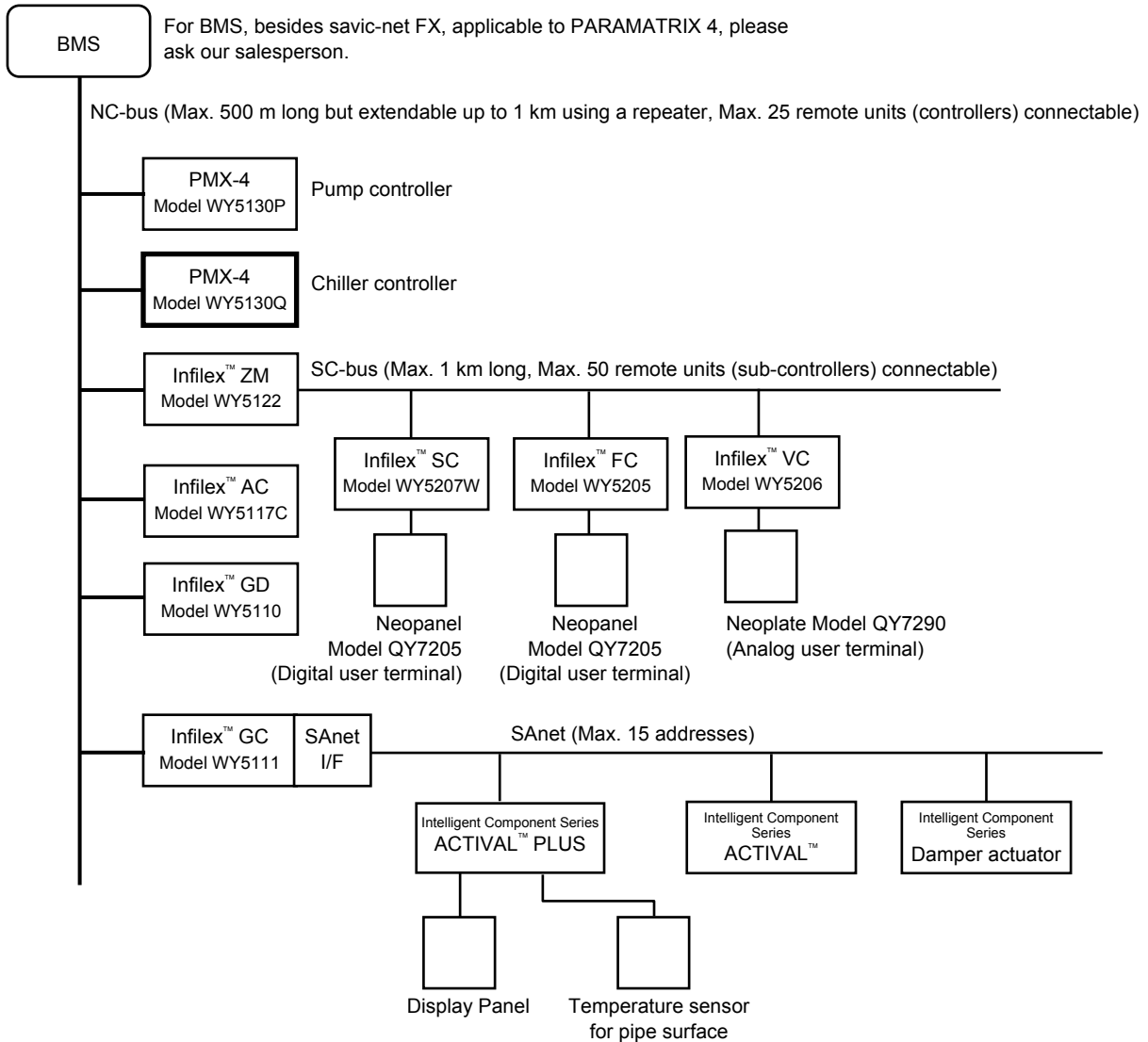
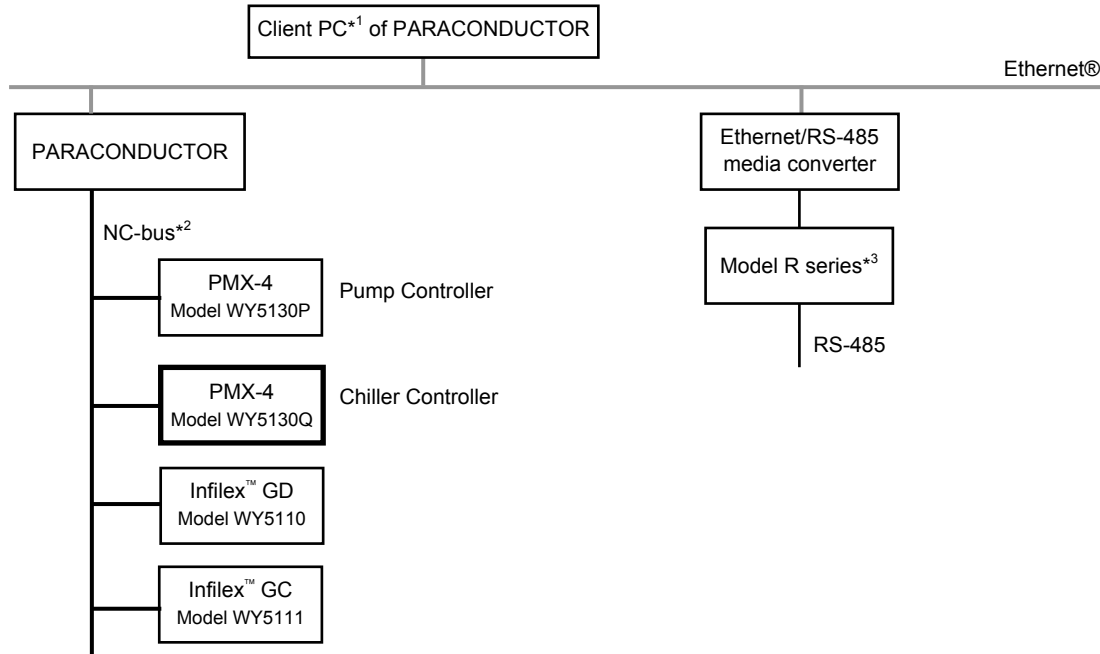

Figure 1. System configuration example: PARAMATRIX 4 with our BMS

**PARAMATRIX™ 4 with PARACONDUCTOR independent system**

PARACONDUCTOR serves as supervisory terminal for heating/cooling system. PARAMATRIX 4 with PARACONDUCTOR offers monitoring, operation, control, data management, etc. of heating/cooling system. PARACONDUCTOR allows you to monitor and operate using the point graph and annunciator software.

PARACONDUCTOR independent system is suitable for medium and small sized building management and for heating/cooling system management separated from the building management.



Notes:

\*1 Recommended specifications of PARACONDUCTOR client PC are as follows.

OS: OS: Microsoft® Windows® 7 or Windows® XP

\*2 Direct digital controllers (DDC) for heating/cooling system control (e.g., cooling pump VVV control) and measurement (e.g., chiller pump power measurement) are connected on the NC-bus line.

\*3 Max. 25 units of Model R series controllers are connectable on the RS-485 line.

Figure 2. System configuration example: PARAMATRIX 4 with PARACONDUCTOR

**PARAMATRIX™ 4 standalone control**

PARAMATRIX 4 without our BMS or PARACONDUCTOR serves as a standalone controller for heating/cooling system.

## Model Numbers

### Model WY5130Q12345678

The following designates the last 8 digits of the model numbers. "WY5130Q" is the base numbers and common to all the model numbers.

Each configured model number includes the basic module and software. I/O modules and OI are not included.

1		2		3		4		5		6		7		8	
Instrumentation type		Number of chillers		Sequence control of:		Pressure control		Valve type (for pressure control)		Network connection*3		Language		Power supply	
1	Single pump system	2	2	3	1 system flow (with energy monitoring)	0	No*1	0	No valve	0	No	1	English	W	100 V AC to 240 V AC
		4	4									4	4 systems flow (with energy monitoring, 4 systems totalization)		
		8	8	4	Korean										
2	Dual pump system	2	2	2	1 system energy	0	No	0	No	0	No	1	English	W	100 V AC to 240 V AC
		4	4									6	4 systems energy (with 4 systems totalization)		
		8	8	4	Korean										

Notes:

\*1 "No valve" of *Valve type (for pressure control)* is only selectable for "No" of *Pressure control*.

\*2 "Nominal 135 Ω feedback potentiometer" or "Current/voltage" of *Valve type (for pressure control)* is selectable for "Proportional bypass valve" of *Pressure control*.

\*3 *Network connection* means network connection with upper system or upper sub-system.

To connect PARAMATRIX 4 with our BMS (System Core Server or PARACONDUCTOR) or PARACONDUCTOR system, select "Yes" of *Network connection*.

## I/O modules

Model number				Description	Abbreviation of modules
RY50				Base model number	—
08	S	0000	I/O module with 8 digital inputs	DI	
16	S	0000	I/O module with 16 digital inputs		
08	D	0000	I/O module with 8 relay outputs (N.O. (normally open) contacts)	DO	
16	D	0000	I/O module with 16 relay outputs (N.O. contacts)		
16	R	0000	I/O module with 8 relay outputs (N.O. contacts) + 8 digital inputs	DO+DI	
08	C	0000	I/O module with 8 relay outputs (N.O./N.C. (normally open/ normally close) contacts)	DOC	
04	T	0000	I/O module with 4 totalizer pulse inputs	TOT	
16	T	0000	I/O module with 16 totalizer pulse inputs		
02	M	0000	I/O module with 2 voltage/current outputs	AO	
04	M	0000	I/O module with 4 voltage/current outputs		
02	A	0000	I/O module with 2 voltage/current inputs (high-speed)	HAI	
04	A	0000	I/O module with 4 voltage/current inputs	AI	
04	P	0000	I/O module with 4 temperature inputs (Pt100)	Pt	
04	P	000K	I/O module with 4 temperature inputs (Pt1000)	Pt	
04	J	0000	I/O module with 2 voltage/current inputs + 2 temperature inputs (Pt100)	AI+Pt	
04	J	000K	I/O module with 2 voltage/current inputs + 2 temperature inputs (Pt1000)	AI+Pt	
01	F	0000	I/O module with 1 Modutrol Motor output	MM	
03	F	0000	I/O module with 3 Modutrol Motor outputs		

Note: PARAMATRIX 4, SW revision is 04 or later, supports the model number RY5004P000K and RY5004J000K.

**AS-952E****OI (optional)**

OI is optional. Separately order OI if needed.

Model number		Description
QY203		Base model number
	1	Language supported: English
	2	Language supported: Chinese simplified
	4	Language supported: Korean
	D0000	Fixed

OI - basic module communication cable

Cable is necessary for OI access to the basic module and is not supplied with the OI.

Use the following OI cable we supply or a cable equivalent to the following.

Part number	Description
83171117-001	EIA/TIA-568 Category 3 (or over) cable (ø0.5 x 4 pairs), 3 m long

### Instrumentation Example Closed single pump system

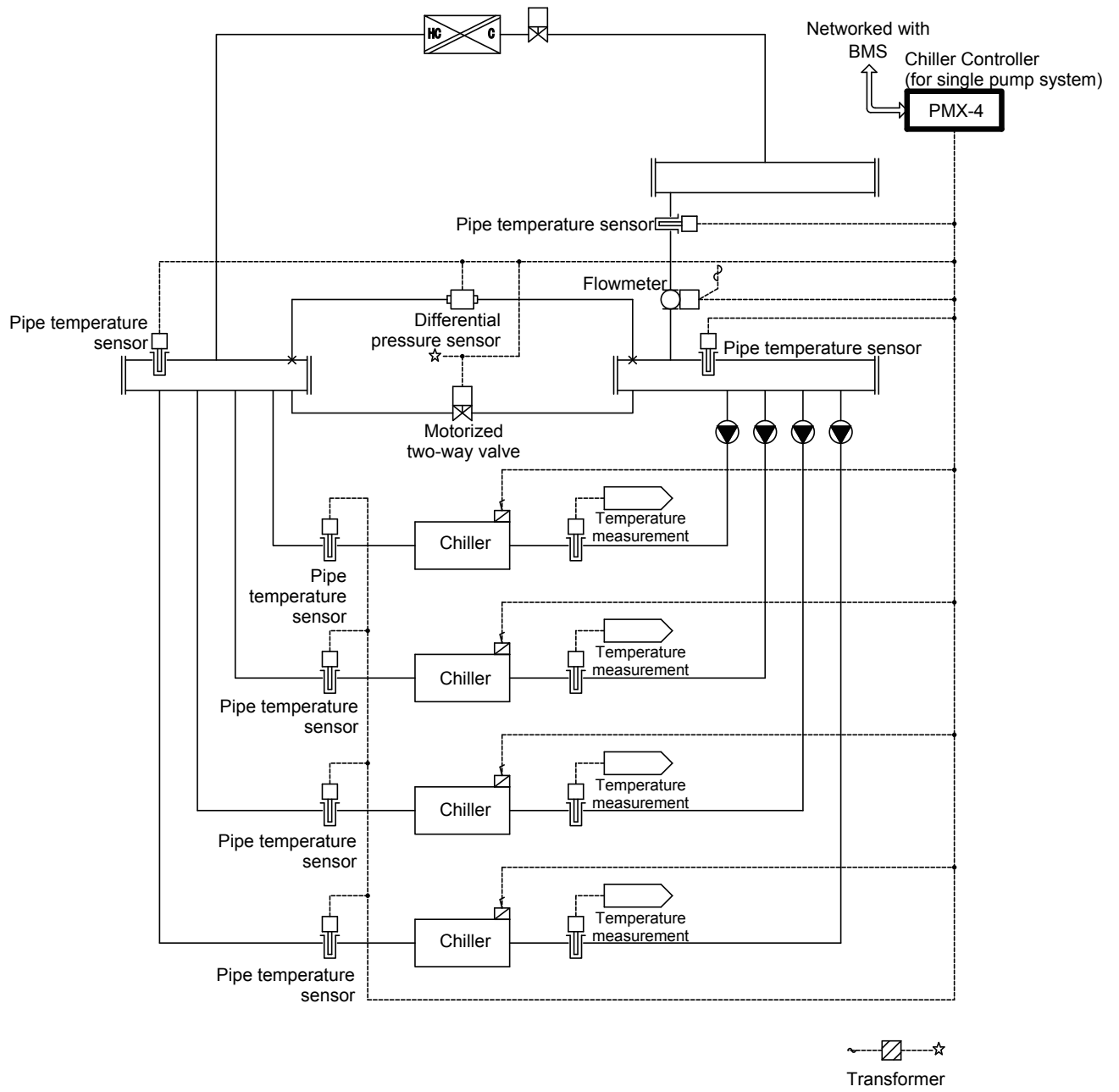

Figure 3. Instrumentation example: Closed single pump system

Closed dual pump system

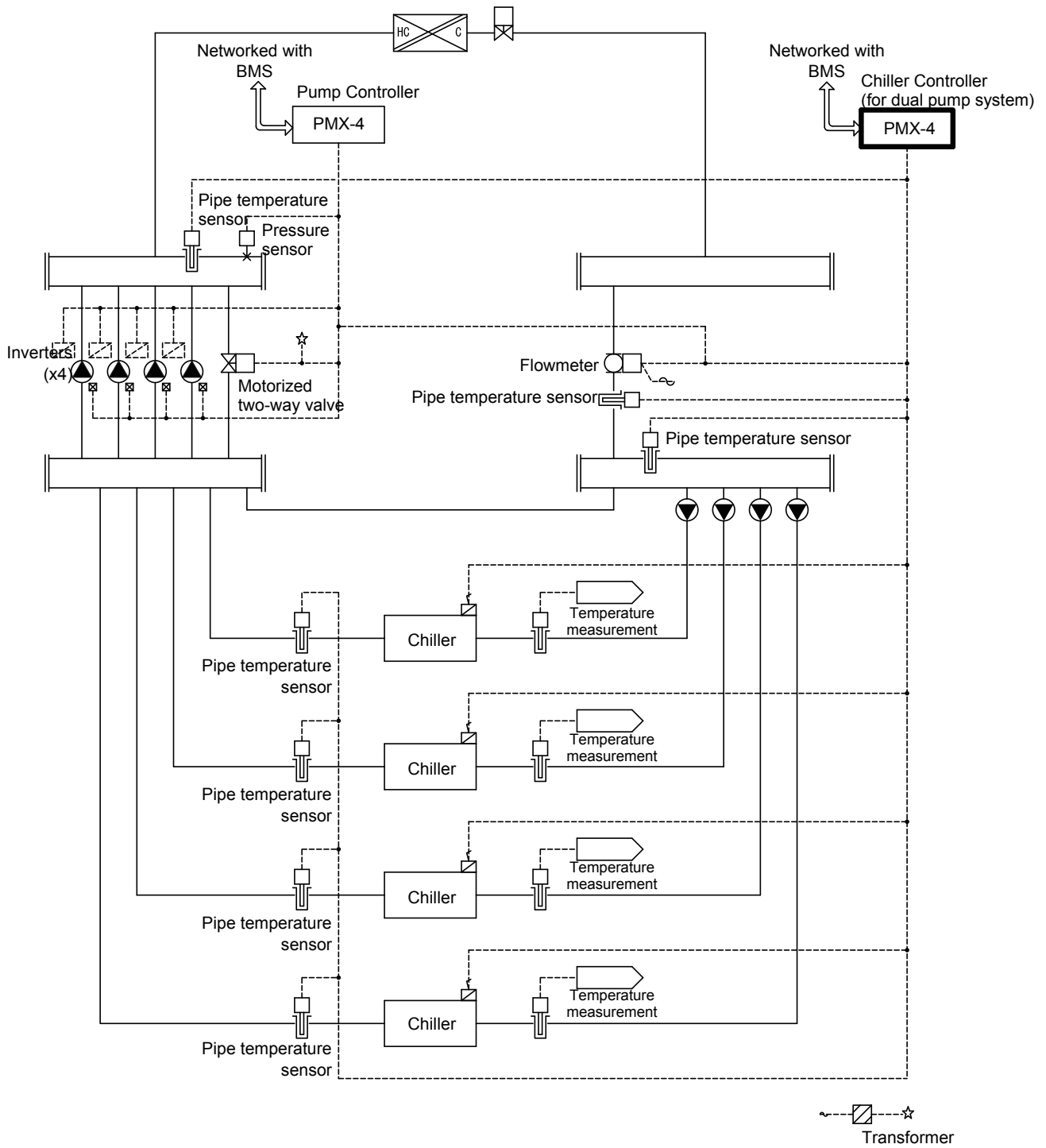
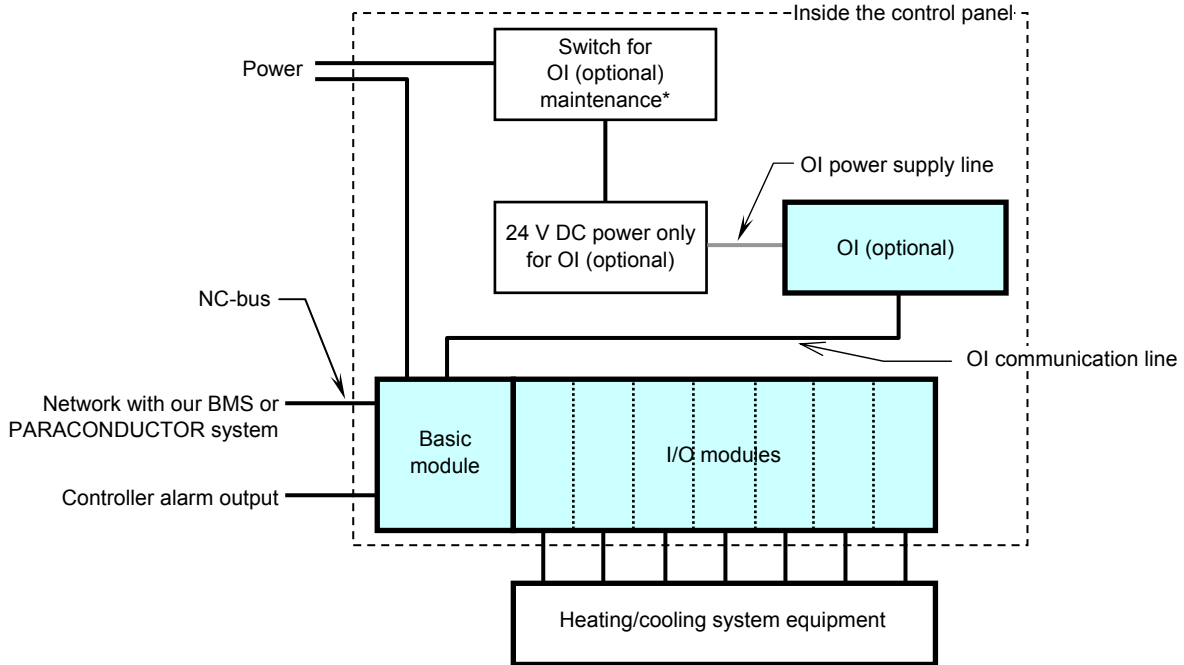

Figure 4. Instrumentation example: Closed dual pump system



**Configurations**

- IMPORTANT:**
- Select the 24 V DC power that meets the specifications of the optional OI and provide it only for the optional OI. Do not run the OI power or communication cable outside the control panel.
  - Provide an outlet only for the engineering tool power supply, and do not connect any other device to the outlet.
  - Do not use a UPS with square wave output for the PARAMATRIX 4 basic module.



Note:

\* Switch for OI maintenance will allow you to replace OI without disconnecting the power to the basic module.

Figure 5. PARAMATRIX 4 configuration diagram

## Model Numbers List

Number of I/O modules to be assembled with the basic module differs depending on the model numbers. I/O modules can be added or removed from the standard I/O modules to fit your application. (1/2)

PARAMATRIX 4 model number (X = Language* <sup>1</sup> )	Number of standard I/O modules* <sup>2</sup>	Instrumentation type (Single or dual pump system)	Number of chillers	Sequence control of:	Pressure control	Valve type (for pressure control)	Network connection
WY5130Q123000XW	6	Single	2	1 system flow	No pressure control	No valve	No
WY5130Q123001XW	6	Single	2	1 system flow	No pressure control	No valve	Yes
WY5130Q123110XW	7	Single	2	1 system flow	Proportional bypass valve	Nominal 135 Ω feedback potentiometer	No
WY5130Q123111XW	7	Single	2	1 system flow	Proportional bypass valve	Nominal 135 Ω feedback potentiometer	Yes
WY5130Q123120XW	6	Single	2	1 system flow	Proportional bypass valve	Current/voltage	No
WY5130Q123121XW	6	Single	2	1 system flow	Proportional bypass valve	Current/voltage	Yes
WY5130Q124000XW	7	Single	2	4 systems flow	No pressure control	No valve	No
WY5130Q124001XW	7	Single	2	4 systems flow	No pressure control	No valve	Yes
WY5130Q124110XW	8	Single	2	4 systems flow	Proportional bypass valve	Nominal 135 Ω feedback potentiometer	No
WY5130Q124111XW	8	Single	2	4 systems flow	Proportional bypass valve	Nominal 135 Ω feedback potentiometer	Yes
WY5130Q124120XW	7	Single	2	4 systems flow	Proportional bypass valve	Current/voltage	No
WY5130Q124121XW	7	Single	2	4 systems flow	Proportional bypass valve	Current/voltage	Yes
WY5130Q143000XW	8	Single	4	1 system flow	No pressure control	No valve	No
WY5130Q143001XW	7	Single	4	1 system flow	No pressure control	No valve	Yes
WY5130Q143110XW	9	Single	4	1 system flow	Proportional bypass valve	Nominal 135 Ω feedback potentiometer	No
WY5130Q143111XW	8	Single	4	1 system flow	Proportional bypass valve	Nominal 135 Ω feedback potentiometer	Yes
WY5130Q143120XW	8	Single	4	1 system flow	Proportional bypass valve	Current/voltage	No
WY5130Q143121XW	7	Single	4	1 system flow	Proportional bypass valve	Current/voltage	Yes
WY5130Q144000XW	9	Single	4	4 systems flow	No pressure control	No valve	No
WY5130Q144001XW	8	Single	4	4 systems flow	No pressure control	No valve	Yes
WY5130Q144110XW	10	Single	4	4 systems flow	Proportional bypass valve	Nominal 135 Ω feedback potentiometer	No
WY5130Q144111XW	9	Single	4	4 systems flow	Proportional bypass valve	Nominal 135 Ω feedback potentiometer	Yes
WY5130Q144120XW	9	Single	4	4 systems flow	Proportional bypass valve	Current/voltage	No
WY5130Q144121XW	8	Single	4	4 systems flow	Proportional bypass valve	Current/voltage	Yes
WY5130Q183000XW	10	Single	8	1 system flow	No pressure control	No valve	No
WY5130Q183001XW	10	Single	8	1 system flow	No pressure control	No valve	Yes
WY5130Q183110XW	11	Single	8	1 system flow	Proportional bypass valve	Nominal 135 Ω feedback potentiometer	No
WY5130Q183111XW	11	Single	8	1 system flow	Proportional bypass valve	Nominal 135 Ω feedback potentiometer	Yes
WY5130Q183120XW	10	Single	8	1 system flow	Proportional bypass valve	Current/voltage	No
WY5130Q183121XW	10	Single	8	1 system flow	Proportional bypass valve	Current/voltage	Yes
WY5130Q184000XW	11	Single	8	4 systems flow	No pressure control	No valve	No
WY5130Q184001XW	11	Single	8	4 systems flow	No pressure control	No valve	Yes
WY5130Q184110XW	12	Single	8	4 systems flow	Proportional bypass valve	Nominal 135 Ω feedback potentiometer	No
WY5130Q184111XW	12	Single	8	4 systems flow	Proportional bypass valve	Nominal 135 Ω feedback potentiometer	Yes
WY5130Q184120XW	11	Single	8	4 systems flow	Proportional bypass valve	Current/voltage	No
WY5130Q184121XW	11	Single	8	4 systems flow	Proportional bypass valve	Current/voltage	Yes

Notes:

\*1 The digit X of the model number designates the language supported. (1 = English, 2 = Chinese simplified, 4 = Korean)

\*2 Number of standard I/O modules can be increased or decreased if needed.

(2/2)

PARAMATRIX 4 model number (X = Language* <sup>1</sup> )	Number of standard I/O modules* <sup>2</sup>	Instrumentation type (Single or dual pump system)	Number of chillers	Sequence control of:	Pressure control	Valve type (for pressure control)	Network connection
WY5130Q222000XW	5	Dual	2	1 system energy	No pressure control	No valve	No
WY5130Q222001XW	5	Dual	2	1 system energy	No pressure control	No valve	Yes
WY5130Q226000XW	6	Dual	2	4 systems energy	No pressure control	No valve	No
WY5130Q226001XW	6	Dual	2	4 systems energy	No pressure control	No valve	Yes
WY5130Q242000XW	7	Dual	4	1 system energy	No pressure control	No valve	No
WY5130Q242001XW	6	Dual	4	1 system energy	No pressure control	No valve	Yes
WY5130Q246000XW	8	Dual	4	4 systems energy	No pressure control	No valve	No
WY5130Q246001XW	7	Dual	4	4 systems energy	No pressure control	No valve	Yes
WY5130Q282000XW	8	Dual	8	1 system energy	No pressure control	No valve	No
WY5130Q282001XW	8	Dual	8	1 system energy	No pressure control	No valve	Yes
WY5130Q286000XW	9	Dual	8	4 systems energy	No pressure control	No valve	No
WY5130Q286001XW	9	Dual	8	4 systems energy	No pressure control	No valve	Yes

## Notes:

\*1 The digit X of the model number designates the language supported. (1 = English, 2 = Chinese simplified, 4 = Korean)

\*2 Number of standard I/O modules can be increased or decreased if needed.

**Components**

PARAMATRIX 4 is composed of the basic module, the I/O modules and the optional operator interface (OI).

**Basic module (Hardware model number: WY5130W0000)**

Basic module serves as control unit for PARAMATRIX 4. It receives data from heating/cooling system equipment through the I/O modules and controls the number of operating chillers and the pressure. The basic module calculates/operates the received data and outputs the results to the heating/cooling system equipment through the I/O modules.

By connecting PARAMATRIX 4 with BMS network, heating/cooling system control is monitored through the BMS client PC.

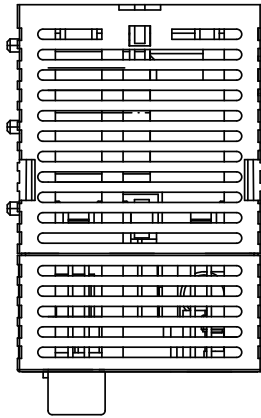

Accessory: Jumper cable for changeover to automatic mode

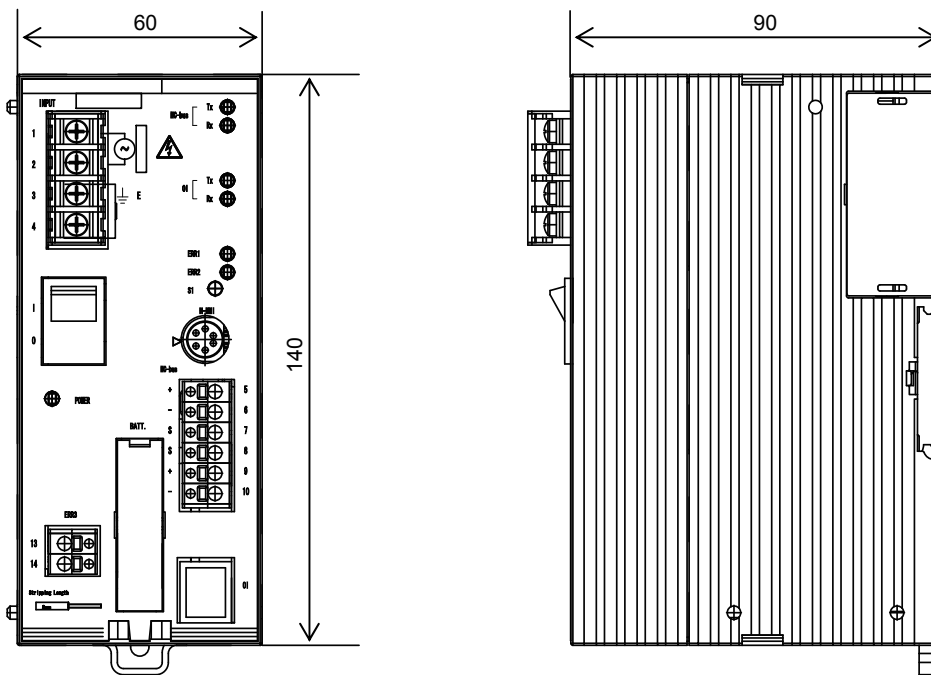

Figure 6. Dimensions (mm): Basic module

**I/O modules (Model RY50XX)**

I/O modules are the input/output sections of the PARAMATRIX 4 and communicate with the basic module. The basic module supplies power to the I/O modules. For the I/O modules applicable to the PARAMATRIX 4 basic module, see **I/O modules** in the **Model Numbers** section.

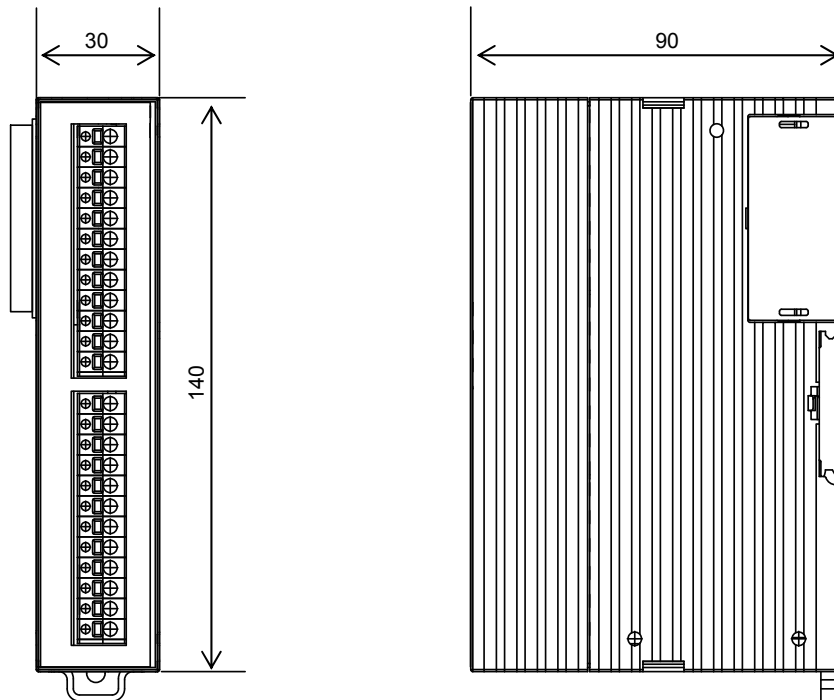
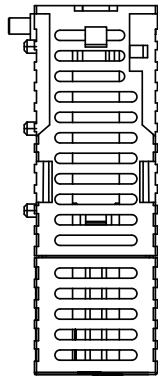
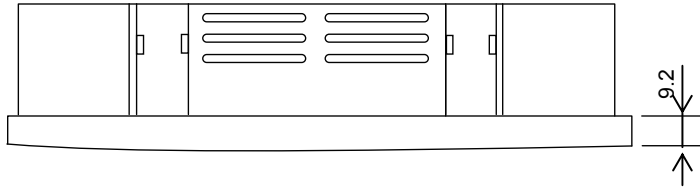

Figure 7. Dimensions (mm): I/O module

**OI (Optional: Model QY203XD0000)**

The optional OI is a PARAMATRIX 4 display-setting device having the following features:

- Adopts color touch-panel LCD.
- Controls access levels classified with password.
- Serves as a parameter-setting device for servicepersons.
- Indicates power supplying status, alarm, and shutdown due to power failure using its LED.



Accessory: Three OI mounting brackets

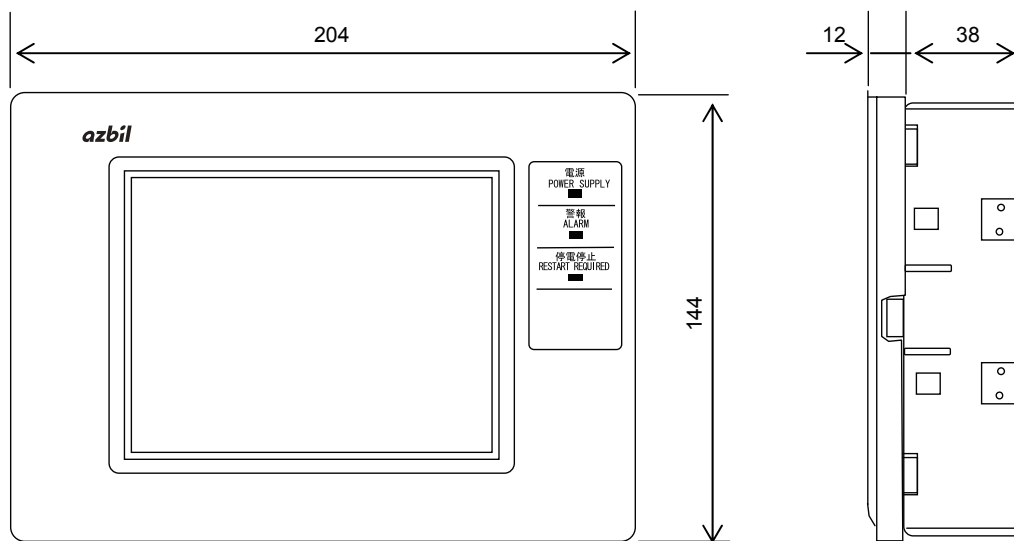

**Note:**

- \* Basic module - OI communication cable is necessary for OI access to the basic module and is not supplied with the OI. Use the cable we supply (OI cable: Part No. 83171117-001) or an equivalent cable.

Figure 8. Dimensions (mm): OI

## Specifications

### Basic module

Item		Specification	
Power supply	Rated voltage	100 V AC to 240 V AC, 50 Hz/60 Hz	
	Operating voltage	85 V AC to 264 V AC	
	Power shutdown detection	80 V AC or less	
	Power consumption	46 VA	
	Inrush current	Max. 40 A (duration: max. 5 ms)	
	Leakage current	1 mA	
Environmental conditions	Rated operating conditions	Ambient temperature	0 °C to 50 °C
		Ambient humidity	10 %RH to 90 %RH (non-condensing)
		Altitude	2000 m or lower
	Transport/storage conditions (of the product in package)	Ambient temperature	-20 °C to 60 °C
		Ambient humidity	5 %RH to 95 %RH (non-condensing)
		Vibration during storage	Max. 3.2 m/s <sup>2</sup> (at 10 Hz to 150 Hz)
LED indication	Operating status	Power	Power ON: POWER LED goes ON (in green). Power OFF: POWER LED goes OFF.
		Major alarm	Major failure alarm or system restart: ERR 1 LED goes ON (in red). Normal operation: ERR 1 LED goes OFF.
		Minor alarm	Minor failure alarm or system restart: ERR 2 LED goes ON (in red). Normal operation: ERR 2 LED goes OFF.
	Communication status	NC-bus	Transmitting: NC-bus TX LED goes ON. Receiving: NC-bus RX LED goes ON.
		OI access	Transmitting: OI TX LED goes ON. Receiving: OI RX LED goes ON.
Weight		420 g	
Major material, color		Modified PPE, light gray	
Communication	NC-bus	Transmission method	Current transmission
		Transmission rate	4800 bps
		Transmission distance	500 m
		Number of remote units	Max 25 remote units (including PARAMATRIX 4) connectable
	OI access	Transmission method	Voltage transmission
		Transmission rate	4800 bps
		Transmission distance	3 m
		Number of OI	1 OI
Controller alarm output*	Alarm output by:	Major failure, power shutdown, initializing, offline mode	
	Output method	PhotoMOS relay output, dry N.O. contact Contact closes (make) during normal state. Contact opens (break) to output alarm.	
	Contact rating	24 V AC/24 V DC, 100 mA or less	
	Applicable voltage	24 V AC/24 V DC ± 15 %	
	Contact ON-resistance	20 Ω or less	
Backup in the event of power failure	RAM, RTC	Lithium battery backup	
	Data file	Nonvolatile memory (flash memory) backup	
Terminal connection	Power supply	M3 screw terminals connection	
	NC-bus	Screwless push-in terminals connection	
	OI access	RJ45 modular connector connection	
	Controller alarm output	Screwless push-in terminals connection	

Note:

- \* Controller alarm output has the overcurrent protective device. Therefore, the overcurrent protective device will keep the contact of the output open (alarm state) once it detects overcurrent (due to shortcircuit, lightning surge, etc). In such a case, turn off and then turn on the power to the controller alarm output circuit. The controller alarm output will return to normal state.

## I/O Modules

(1/2)

Item		Specification		
Common	Environmental conditions	Rated operating conditions	Ambient temperature	0 °C to 50 °C
			Ambient humidity	10 %RH to 90 %RH (Non-condensing)
			Altitude	2000 m or lower
		Transport and storage conditions	Vibration	Max. 3.2 m/s <sup>2</sup> (at 10 Hz to 150 Hz)
			Ambient temperature	-20 °C to 60 °C
			Ambient humidity	5 %RH to 95 %RH (Non-condensing)
	Major materials, color		Modified PPE, light gray	
	Terminals connection		Screwless push-in terminals connection	
	Communication		Number of I/O modules	Max. 16 I/O modules connectable
	Inputs	Digital input, totalizer pulse input* <sup>1</sup>	Current	5 mA DC (typ.)
Voltage			24 V DC (typ.)	
Connectable output			Dry contact or open collector	
Allowable contact ON-resistance			100 Ω or less	
Allowable contact OFF-resistance			100 kΩ or more	
Allowable ON residual voltage			1 V DC or less	
Temperature input		Input signal	Pt RTD (Pt100 Ω/0 °C) Pt RTD (Pt1000 Ω/0 °C)	
		Measuring range	-50 °C to 100 °C	
		Allowable setting range	0 °C to 100 °C / 0 °C to 50 °C / -20 °C to 80 °C / -20 °C to 30 °C / -50 °C to 100 °C	
Voltage input		Input voltage range	0 V DC to 5 V DC / 0 V DC to 10 V DC / 1 V DC to 5 V DC / 2 V DC to 10 V DC	
		Input impedance	500 kΩ (typ.)	
Current input		Input current range	4 mA DC to 20 mA DC	
		Input impedance	250 Ω (typ.)	
Voltage/current input (high-speed)* <sup>2</sup>		Insulation between channels	Insulated	
		Power supply	24 V DC, 0.6 W or less (for supplying power to a sensor to connect)	
	Measuring period	200 ms		
Outputs	Relay output (N.O. contact)	Output method	Relay output, N.O. contact (N.O. contacts use the same common line.)	
		Contact rating	24 V AC, 0.5 A or less (Inductive load: cosφ = 0.4 or more) 24 V DC, 0.5 A or less	
		Minimum applicable load	5 V DC, 10 mA DC	
	Relay output (N.O./N.C. contact)	Output method	Relay output, N.O./N.C. contact	
		Contact rating	24 V AC, 1 A or less (Inductive load: cosφ = 0.4 or more) 24 V DC, 1 A or less	
		Minimum applicable load	5 V DC, 100 mA DC	
	Voltage output	Output voltage range	0 V DC to 5 V DC / 0 V DC to 10 V DC / 1 V DC to 5 V DC / 2 V DC to 10 V DC	
		Minimum load resistance	10 kΩ	
	Current output	Output current range	4 mA DC to 20 mA DC	
		Maximum load resistance	500 Ω	
	Modutrol Motor output	Output method	Relay output, N.O. contact	
		Contact rating	24 V AC / 24 V DC, 1 A or less	
		Input signal	3-wire type feedback potentiometer	
		Load resistance range	100 Ω to 10 kΩ	

Notes:

\*1 The pulse width and pulse intervals must satisfy three conditions shown in the right figure.

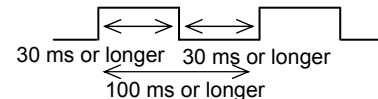

\*2 Other specifications of the voltage/current input (high-speed) are the same as the specifications of the voltage input and of the current input.



(2/2)

Item		Specification
Weight	DI module	160 g
	DO module	210 g
	DO module + DI module	190 g
	DOC module	230 g
	TOT module	160 g
	AO module	170 g
	AI module	160 g
	HAI module	180 g
	Pt module	160 g
	AI module + Pt module	160 g
MM module	190 g	

**OI (Optional)**

Item		Specification	
Power supply	Rated voltage	24 V DC $\pm$ 10 %	
	Power consumption	6 W	
Environmental conditions	Rated operating conditions	Ambient temperature	0 °C to 45 °C
		Ambient humidity	20 %RH to 85 %RH (non-condensing)
		Vibration	Max. 3.2 m/s <sup>2</sup> (at 10 to 150 Hz)
	Transport/storage conditions (of the product in package)	Ambient temperature	-20 °C to 60 °C
		Ambient humidity	10 %RH to 85 %RH (non-condensing)
		Vibration during storage	Max. 3.2 m/s <sup>2</sup> (at 10 Hz to 150 Hz)
Vibration during transport	Max. 9.8 m/s <sup>2</sup> (at 10 Hz to 150 Hz)		
Display	Main display	5.7-inch STN color LCD (320 x 240 dots) with backlight	
	LED	Power	Power ON: POWER SUPPLY LED goes ON (in green). Power OFF: POWER SUPPLY LED goes OFF.
		Alarm	Point in trouble: ALARM LED goes ON (in red). Normal operation: ALARM LED goes OFF.
		Power shutdown	Point requiring to restart at power return: RESTART REQUIRED LED goes ON (in red). Normal operation: RESTART REQUIRED LED goes OFF.
Operation	Main display	Analog touch panel	
	Dip switch	For switch to boot mode, reset, touch panel adjustment	
	Knob	Main display contrast adjustment	
Weight		1.0 kg	
Major material, color		Housing: Modified PPE, light gray Base: Cold-reduced carbon steel (JIS* SPCC) with 1.0 mm thick galvanization * JIS: Japanese Industrial Standards	
Communication	OI access	Transmission method	Voltage transmission
		Transmission rate	4800 bps
		Transmission distance	3 m
		Number of OI	1 OI connectable to 1 basic module
Backup in the event of power failure	RAM, RTC	Lithium battery backup	
Terminal connection	Power supply	M3.5 screw terminals connection	
	OI access (to basic module)	RJ45 modular connector connection	

**Required specifications for OI 24 V DC power supply**

Item	Specification
Capacity	30 W or more
Ripple voltage	2 % or less
Line regulation	0.5 % or less
Load regulation	1.5 % or less
Temperature coefficient	0.05 %/°C or less
Startup time	1 s or less
Output holding time	10 ms or more
Overcurrent protection	Needed

## Wiring specifications

### Basic module

Item	Specification	Wiring length	Note
Power supply	JIS IV or JIS CVV 2.0 mm <sup>2</sup> or more	—	—
Ground	JIS IV or JIS CVV 2.0 mm <sup>2</sup> or more	—	100 Ω or lower ground resistance required
Communication	NC-bus IPEV-S*: 0.9 mm <sup>2</sup> * IPEV-S is a cable standard provided by Fujikura Ltd.	500 m	—
	OI access EIA/TIA-568 Category 3 (or over) cable (ø0.5 x 4 pairs)	3 m	Use OI cable (Part No. 83171117-001) or equivalent cable.
Controller alarm output	JIS IV, JIS CVV, or KPEV®* 1.25 mm <sup>2</sup> * KPEV is a cable standard provided by Furukawa Electric Co., Ltd.	30 m	If CE Marking is not required for your PARAMATRIX 4, up to 100 m wiring length is acceptable.

### I/O modules\*<sup>1</sup>

Item	Specifications	Wiring length* <sup>2</sup>
Temperature input	JIS IV, JIS CVV, or KPEV® 1.25 mm <sup>2</sup>	100 m
Voltage / current input	JIS IV, JIS CVV, or KPEV® 1.25 mm <sup>2</sup>	100 m
Voltage / current output	JIS IV, JIS CVV, or KPEV® 0.9 mm <sup>2</sup> /1.25 mm <sup>2</sup>	100 m
Modutrol Motor output	JIS IV, JIS CVV, or KPEV® 1.25 mm <sup>2</sup>	100 m
Digital input	JIS IV, JIS CVV, or KPEV® 0.5 mm <sup>2</sup> /0.75 mm <sup>2</sup> /0.9 mm <sup>2</sup> /1.25 mm <sup>2</sup>	100 m
Relay output	JIS IV, JIS CVV, or KPEV® 1.25 mm <sup>2</sup>	100 m

Notes:

- \*1 Screwless push-in terminals are provided on I/O modules. Strip the wire sheath and connect the wires.  
Sheath strip length: 8 mm (Pin terminal cannot be used.)
- \*2 Wiring length shown above is the total wiring length from the I/O module terminals to the terminals of a device in connection, including the wiring length to and from an external terminal block.

### OI (Optional)

Item	Specification	Wiring length	Note
Power supply	JIS IV or JIS CVV 2.0 mm <sup>2</sup>	3 m	—
Ground	JIS IV or JIS CVV 2.0 mm <sup>2</sup> or more	—	100 Ω or lower ground resistance required
Communication (OI access)	EIA/TIA-568 Category 3 (or over) cable (ø0.5 x 4 pairs)	3 m	Use OI cable (Part No. 83171117-001) or equivalent cable.

## CE Marking Conformity

This product must be installed in a panel cabinet. Besides, the product in the panel cabinet must be out of reach of unauthorized people who are not well-trained for electric facilities.

This product complies with the following Electromagnetic Compatibility (EMC) and the Low Voltage Directive (LVD).

EMC : EN61326-1 Class A, Table 2 (For use in an industrial electromagnetic environment)

LVD : EN61010-1 Overvoltage category II

Pollution degree 2

## Input/Output Configurations

### Single pump system, without pressure control, with network connection (Model WY5130Q1XX001XW)

Input/output		Description
DI	Group command	Executed using the OI. Group command setting can be changed so that the group command is input by DI signal.
	Automatic/manual changeover	ON: Automatic, OFF: Manual
	Target unit power status	Input to control power failure restoration for the chiller power supply system separate from the PARAMATRIX 4 power supply system.
	Chiller n* <sup>1</sup> status	Input as return signal from the chiller n within 2 seconds after ON/OFF command.
	Chiller n* <sup>1</sup> alarm	
	Chiller n* <sup>1</sup> shutdown	Input to forcibly shut down the chiller n. Point type of the chiller n shutdown can be changed so that the chiller n is shut down using BMS client PC.
DO	Increase notice	Dry N.O. contact
	Chiller n* <sup>1</sup> starting	Dry N.O. contact
AI	Supply water temperature	RTD Pt100 Ω (-20 °C to 80 °C)
	Return water temperature (header side)	RTD Pt100 Ω (-20 °C to 80 °C)
	System m* <sup>2</sup> load flow rate	4 mA DC to 20 mA DC
	Differential pressure between headers	4 mA DC to 20 mA DC
	Chiller n* <sup>1</sup> outlet temperature	RTD Pt100 Ω (-20 °C to 80 °C)
	System m* <sup>2</sup> return water temperature (load side)	RTD Pt100 Ω (-20 °C to 80 °C)
AO	Supply water temperature setting	4 mA DC to 20 mA DC
	Differential pressure setting	4 mA DC to 20 mA DC

Notes:

\*1 n = 1 to 2 / 1 to 4 / 1 to 8 (depending on the model number)

\*2 m = 1 / 1 to 4 (depending on the model number)

### Single pump system, without pressure control, without network connection (Model WY5130Q1XX000XW)

Input/output		Description
DI	Group command	Input by DI signal. Group command setting can be changed so that the group command is executed using the OI.
	Daytime/nighttime changeover	Input by DI signal to switch between daytime and nighttime. Point type of the daytime/nighttime changeover can be changed so that the daytime/nighttime is changed over using the OI.
	Cooling/heating changeover	Input by DI signal to switch between cooling and heating. Point type of the cooling/heating changeover can be changed so that the cooling/heating is changed over using the OI.
	Automatic/manual changeover	ON: Automatic, OFF: Manual
	Target unit power status	Input to control power failure restoration for the chiller power supply system separate from the PARAMATRIX 4 power supply system.
	Chiller n* <sup>1</sup> status	Input as return signal from the chiller n within 2 seconds after ON/OFF command.
	Chiller n* <sup>1</sup> alarm	
	Chiller n* <sup>1</sup> shutdown	Input to forcibly shut down the chiller n. Point type of the chiller n shutdown can be changed so that the pump n is shut down using the OI.
DO	Increase notice	Dry N.O. contact
	Chiller n* <sup>1</sup> starting	Dry N.O. contact
AI	Supply water temperature	RTD Pt100 Ω (-20 °C to 80 °C)
	Return water temperature (header side)	RTD Pt100 Ω (-20 °C to 80 °C)
	System m* <sup>2</sup> load flow rate	4 mA DC to 20 mA DC
	Differential pressure between headers	4 mA DC to 20 mA DC
	Chiller n* <sup>1</sup> outlet temperature	RTD Pt100 Ω (-20 °C to 80 °C)
	System m* <sup>2</sup> return water temperature (load side)	RTD Pt100 Ω (-20 °C to 80 °C)
AO	Supply water temperature setting	4 mA DC to 20 mA DC
	Differential pressure setting	4 mA DC to 20 mA DC

Notes:

\*1 n = 1 to 2 / 1 to 4 / 1 to 8 (depending on the model number)

\*2 m = 1 / 1 to 4 (depending on the model number)

**Single pump system, with proportional bypass valve, with network connection (Model WY5130Q1XX1X1XW)**

Input/output		Description
DI	Group command	Executed using the OI. Group command setting can be changed so that the group command is input by DI signal.
	Automatic/manual changeover	ON: Automatic, OFF: Manual
	Target unit power status	Input to control power failure restoration for the chiller power supply system separate from the PARAMATRIX 4 power supply system.
	Chiller n <sup>*1</sup> status	Input as return signal from the chiller n within 2 seconds after ON/OFF command.
	Chiller n <sup>*1</sup> alarm	
	Chiller n <sup>*1</sup> shutdown	Input to forcibly shut down the chiller n. Point type of the chiller n shutdown can be changed so that the chiller n is shut down using BMS client PC.
	Primary pump status	Input to receive ON (active) or OFF (inactive) status of primary pumps. (OFF is input when all the primary pumps are inactive. ON is input when even one of the primary pumps is active.)
DO	Increase notice	Dry N.O. contact
	Chiller n <sup>*1</sup> starting	Dry N.O. contact
AI	Supply water temperature	RTD Pt100 Ω (-20 °C to 80 °C)
	Return water temperature (header side)	RTD Pt100 Ω (-20 °C to 80 °C)
	System m <sup>*2</sup> load flow rate	4 mA DC to 20 mA DC
	Differential pressure between headers	4 mA DC to 20 mA DC
	Chiller n <sup>*1</sup> outlet temperature	RTD Pt100 Ω (-20 °C to 80 °C)
	System m <sup>*2</sup> return water temperature (load side)	RTD Pt100 Ω (-20 °C to 80 °C)
AO	Supply water temperature setting	4 mA DC to 20 mA DC
	Bypass valve	Motor output or 4 mA DC to 20 mA DC

Notes:

\*1 n = 1 to 2 / 1 to 4 / 1 to 8 (depending on the model number)

\*2 m = 1 / 1 to 4 (depending on the model number)

**Single pump system, with proportional bypass valve, without network connection (Model WY5130Q1XX1X0XW)**

Input/output		Description
DI	Group command	Input by DI signal. Group command setting can be changed so that the group command is executed using the OI.
	Daytime/nighttime changeover	Input by DI signal to switch between daytime and nighttime. Point type of the daytime/nighttime changeover can be changed so that the daytime/nighttime is changed over using the OI.
	Cooling/heating changeover	Input by DI signal to switch between cooling and heating. Point type of the cooling/heating changeover can be changed so that the cooling/heating is changed over using the OI.
	Automatic/manual changeover	ON: Automatic, OFF: Manual
	Target unit power status	Input to control power failure restoration for the chiller power supply system separate from the PARAMATRIX 4 power supply system.
	Chiller n <sup>*1</sup> status	Input as return signal from the chiller n within 2 seconds after ON/OFF command.
	Chiller n <sup>*1</sup> alarm	
	Chiller n <sup>*1</sup> shutdown	Input to forcibly shut down the chiller n. Point type of the chiller n shutdown can be changed so that the chiller n is shut down using BMS client PC.
	Primary pump status	Input to receive ON (active) or OFF (inactive) status of primary pumps. (OFF is input when all the primary pumps are inactive. ON is input when even one of the primary pumps is active.)
DO	Increase notice	Dry N.O. contact
	Chiller n <sup>*1</sup> starting	Dry N.O. contact
AI	Supply water temperature	RTD Pt100 Ω (-20 °C to 80 °C)
	Return water temperature (header side)	RTD Pt100 Ω (-20 °C to 80 °C)
	System m <sup>*2</sup> load flow rate	4 mA DC to 20 mA DC
	Differential pressure between headers	4 mA DC to 20 mA DC
	Chiller n <sup>*1</sup> outlet temperature	RTD Pt100 Ω (-20 °C to 80 °C)
	System m <sup>*2</sup> return water temperature (load side)	RTD Pt100 Ω (-20 °C to 80 °C)
AO	Supply water temperature setting	4 mA DC to 20 mA DC
	Bypass valve	Motor output or 4 mA DC to 20 mA DC

Notes:

\*1 n = 1 to 2 / 1 to 4 / 1 to 8 (depending on the model number)

\*2 m = 1 / 1 to 4 (depending on the model number)

**Dual pump system, with network connection (Model WY5130Q2XX001XW)**

Input/output		Description
DI	Group command	Executed using the OI. Group command setting can be changed so that the group command is input by DI signal.
	Automatic/manual changeover	ON: Automatic, OFF: Manual
	Target unit power status	Input to control power failure restoration for the chiller power supply system separate from the PARAMATRIX 4 power supply system.
	Chiller n* <sup>1</sup> status	Input as return signal from the chiller n within 2 seconds after ON/OFF command.
	Chiller n* <sup>1</sup> alarm	
	Chiller n* <sup>1</sup> shutdown	Input to forcibly shut down the chiller n. Point type of the chiller n shutdown can be changed so that the chiller n is shut down using BMS client PC.
DO	Chiller n* <sup>1</sup> starting	Dry N.O. contact
AI	Supply water temperature	RTD Pt100 Ω (-20 °C to 80 °C)
	Return water temperature (header side)	RTD Pt100 Ω (-20 °C to 80 °C)
	System m* <sup>2</sup> load flow rate	4 mA DC to 20 mA DC
	Chiller n* <sup>1</sup> outlet temperature	RTD Pt100 Ω (-20 °C to 80 °C)
	System m* <sup>2</sup> return water temperature (load side)	RTD Pt100 Ω (-20 °C to 80 °C)
AO	Supply water temperature setting	4 mA DC to 20 mA DC

Notes:

\*1 n = 1 to 2 / 1 to 4 / 1 to 8 (depending on the model number)

\*2 m = 1 / 1 to 4 (depending on the model number)

**Dual pump system, without network connection (Model WY5130Q2XX000XW)**

Input/output		Description
DI	Group command	Input by DI signal. Group command setting can be changed so that the group command is executed using the OI.
	Daytime/nighttime changeover	Input by DI signal to switch between daytime and nighttime. Point type of the daytime/nighttime changeover can be changed so that the daytime/nighttime is changed over using the OI.
	Cooling/heating changeover	Input by DI signal to switch between cooling and heating. Point type of the cooling/heating changeover can be changed so that the cooling/heating is changed over using the OI.
	Automatic/manual changeover	ON: Automatic, OFF: Manual
	Target unit power status	Input to control power failure restoration for the chiller power supply system separate from the PARAMATRIX 4 power supply system.
	Chiller n* <sup>1</sup> status	Input as return signal from the chiller n within 2 seconds after ON/OFF command.
	Chiller n* <sup>1</sup> alarm	
	Chiller n* <sup>1</sup> shutdown	Input to forcibly shut down the chiller n. Point type of the chiller n shutdown can be changed so that the chiller n is shut down using BMS client PC.
DO	Chiller n* <sup>1</sup> starting	Dry N.O. contact
AI	Supply water temperature	RTD Pt100 Ω (-20 °C to 80 °C)
	Return water temperature (header side)	RTD Pt100 Ω (-20 °C to 80 °C)
	System m* <sup>2</sup> load flow rate	4 mA DC to 20 mA DC
	Chiller n* <sup>1</sup> outlet temperature	RTD Pt100 Ω (-20 °C to 80 °C)
	System m* <sup>2</sup> return water temperature (load side)	RTD Pt100 Ω (-20 °C to 80 °C)
AO	Supply water temperature setting	4 mA DC to 20 mA DC

Notes:

\*1 n = 1 to 2 / 1 to 4 / 1 to 8 (depending on the model number)

\*2 m = 1 / 1 to 4 (depending on the model number)

## Control of Units (Chillers)

### Operation management

#### 1. Automatic/manual changeover

The automatic and the manual operations are changed over by operating our BMS client PC, operating the OI, or the DI signal input. The DI to switch to the manual operation has the highest priority. Besides the DI, the last automatic/manual changeover has the priority.

Note: When you start or stop the unit after changing the operation mode from automatic to manual, wait more than 10 sec to start or stop the unit

#### Manual operation:

Maintains the last unit operating status before changeover to the manual operation and disables the sequence control.

During the manual operation, the units are manually controlled (started and stopped) on site.

#### Automatic operation:

Executes the sequence control, after the group command ON is executed.

#### 2. Group command

For models with network connection, the group command is executed by operating our BMS client PC or the OI. (Group command setting can be changed so that the group command is input by DI signal.)

For models without network connection, the group command is input by DI signal. (Group command setting can be changed so that the group command is executed by operating the OI.)

Note:

Group command DI for anti-freezing control will be enabled if the group command is set to be executed by operating our BMS client PC or the OI.

#### Group command ON:

Executes the sequence control in the automatic operation.

#### Group command OFF:

Stops all the units in the automatic operation.

#### 3. Daytime/nighttime mode changeover

For models with network connection, daytime and nighttime modes are changed over by operating our BMS client PC or the OI. (The point type can be changed so that the daytime/nighttime changeover is input by the DI signal.)

For models without network connection, the daytime and nighttime modes are changed over by DI signal input. (The point type can be changed so that the daytime and nighttime modes are changed over by operating the OI.)

Note:

Operating sequence table, maximum number of operating units, start load are changed over using the daytime/nighttime mode changeover.

#### 4. Heating/cooling mode changeover

For models with network connection, heating and cooling modes are changed over by operating our BMS client PC or the OI. (The point type can be changed so that the heating/cooling changeover is input by the DI signal.)

For models without network connection, the heating and cooling modes are changed over by the DI signal input. (The point type can be changed so that the heating and cooling modes are changed over by operating the OI.)

Note:

Operating sequence table, maximum number of operating units, start load are changed over using the heating/cooling mode changeover.

### Sequence control management

#### 1. Sequence control method

PARAMATRIX 4 Chiller Controller offers one of the following three methods according to its models (instrumentation types).

##### 1) Flow rate method (for single pump system)

Interprets the flow rate as the load for the sequence control, compares it with the total capacity of the running units, and determines the optimum number of the units to run.

The function of totalizing up to 4 systems flow rate is available depending on the models.

##### 2) Energy method (for dual pump system)

Calculates energy from supply water temperature, return water temperature and load flow rate, interprets the calculated energy as the load for the sequence control, compares it with the total capacity of the running units, and determines the optimum number of the units to run. The function of calculating and totalizing up to 4 energy systems is available depending on the models.

Note:

The energy method can be changed to the flow rate method is necessary.

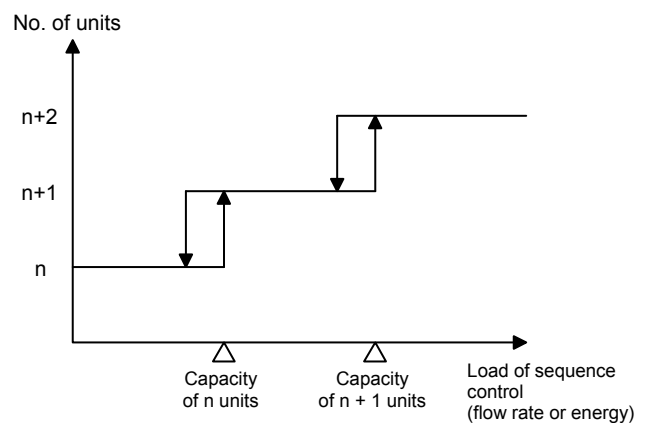

Figure 9. Sequence control

#### 3) Temperature method

Sequentially control the units by increasing based on the supply water temperature and decreasing based on the return water temperature.

Note:

Temperature method applies to a heating/cooling system with no flowmeter.

2. Operating sequence changeover methods  
The following five operation sequence changeover methods are selectable.

1) Sequential method

Starts and stops the units in the fixed order.  
The unit with the highest priority starts up first and shuts down last.

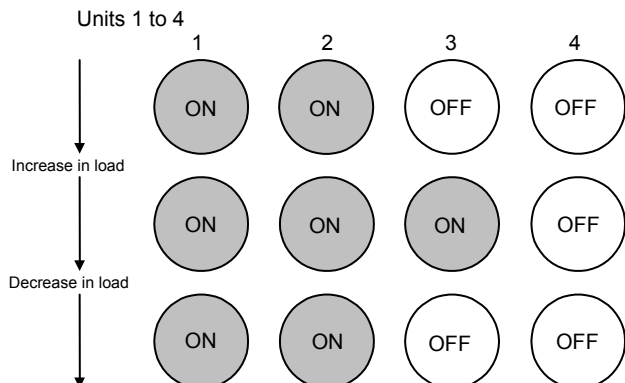

Figure 10. Operating sequence changeover: Sequential method

2) Sequential method with base unit changeover

Shifts the operating sequence after a group command OFF so that the unit started up first will start up last next time. This is a kind of the sequential method.

3) Rotational method

Controls the operating sequence to average the units runtime.

The following two methods (a. and b.) are selectable.

a. Rotates the operating sequence so that a unit which has been continuously inactive for the longest time will start up and a unit which has been continuously active for the longest time will shut down.

Note:

Each unit runtime is not compared to decide the operating sequence in this method.

b. Rotates the operating sequence to surely smooth the runtime by starting a unit with the shortest runtime first and by stopping a unit with the longest cumulative runtime first.

Note:

Units operation are controlled based on their cumulative runtime. If a unit runtime is reset to "0," the reset unit will always start up first.

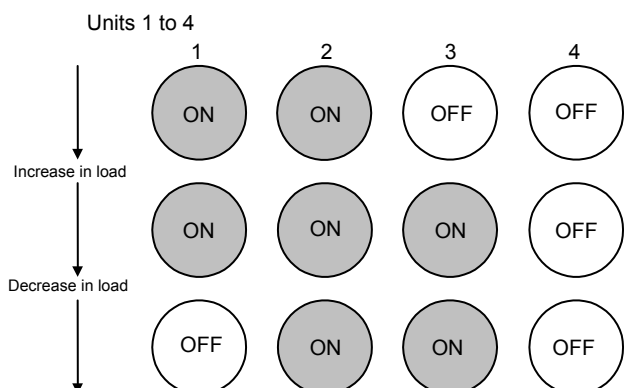

Figure 11. Operating sequence changeover: Rotational method a.

4) Rotational method with forced increase

Rotates the operating sequence by forcibly increasing the active units when no increase in the active units occurs during a certain time period. Forced increase is executed periodically or at the preset time.

5) Programming method

Categorizes the units into up to 6 groups (types) of capacities, classifies each groups into up to 12 levels, and combines the units to operate. (See Tables 1 and 2.) The units operating sequence of each group is changed in the rotational method. The programming method applies to operating the units with different capacities.

Note:

a. or b. of the rotational methods is selectable for the programming method.

Table 1. Group setting example: Programming method (1 unit with small capacity is registered to Group 1, and 3 units with large capacity are registered to Group 2.)

Group	Unit number			
1	1	—	—	—
2	2	3	4	—
3	—	—	—	—
4	—	—	—	—
5	—	—	—	—
6	—	—	—	—

Table 2. Level setting example: Programming method

Level	Number of units						Load conditions for each level
	Group						
	1	2	3	4	5	6	
1	1	0	0	0	0	0	Load ≤ Group 1 unit capacity
2	0	1	0	0	0	0	Group 1 unit capacity < Load ≤ Group 2 unit capacity
3	1	1	0	0	0	0	Group 2 unit capacity < Load ≤ Group 1 + Group 2 unit capacities
4	0	2	0	0	0	0	Group 1 + Group 2 unit capacities < Load ≤ Group 2 unit capacity x 2
5	1	2	0	0	0	0	Group 2 unit capacity x 2 < Load ≤ Group 1 unit capacity + Group 2 unit capacity x 2
6	0	3	0	0	0	0	Group 1 unit capacity + Group 2 unit capacity x 2 < Load ≤ Group 2 unit capacity x 3
7	1	3	0	0	0	0	Group 2 unit capacity x 3 < Load
8	-	-	-	-	-	-	—
9	-	-	-	-	-	-	—
10	-	-	-	-	-	-	—
11	-	-	-	-	-	-	—
12	-	-	-	-	-	-	—

3. Operating sequence table

The operating sequence is set for each of the following four tables:

- Heating daytime mode
- Heating nighttime mode
- Cooling daytime mode
- Cooling nighttime mode

The operating sequence changeover method is common to all of the tables. When the table is changed over, the sequence control at unit startup is executed as explained later.

4. Operating sequence adjustment (for sequential method)

There are two selectable methods to adjust operating sequence for the changeover of operating sequence tables, for the changeover from manual to automatic operation, and for the restoration from a unit failure or a forced shutdown. The operating sequence adjustment is available only for the sequential method.

1) Operating units priority method

Gives the priority to the active units (in ON state) over the inactive units (in OFF state) to operate. This minimizes the times of start/stop operation.

2) Sequence setting priority method

Always starts and stops the units according to the predetermined operating sequence setting.

For adjusting the operating sequence, start operation of some units and stop operation of other units may be simultaneously required. If the start and stop operations are performed simultaneously, the unit capacities may drop due to abnormal pressure rise or unit start delay. To prevent this, ON/OFF simultaneous process will be executed. The following two ON/OFF simultaneous processes are selectable.

ON priority process:

Sequentially starts the units scheduled to start up first, waits till the effect waiting time for startup (startup time) passes, and then sequentially stops the units scheduled to shut down.

OFF priority process:

Sequentially stops the units scheduled to shut down first, waits till the effect waiting time for shutdown (remain run time) passes, and then sequentially starts the units scheduled to start up.

5. Capacity setting

Unit capacities are set by communicating with the BMS client PC or with the OI. Flow rate is set for the single pump system capacity, and energy is set for the dual pump system capacity.

Operating sequence adjustment examples

Operating units priority method (increase in load)

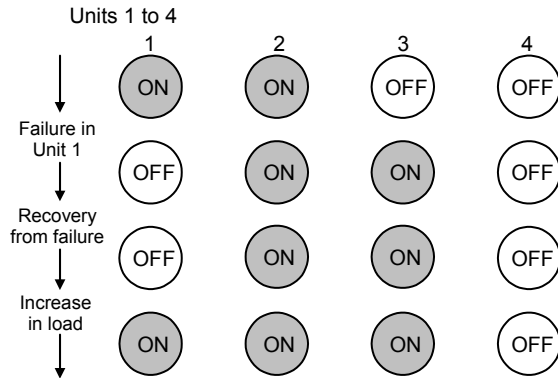

Operating units priority method (decrease in load)

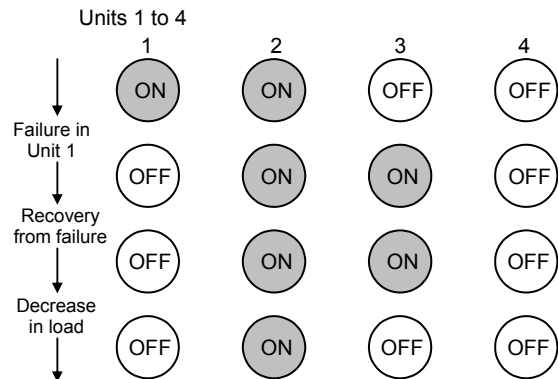
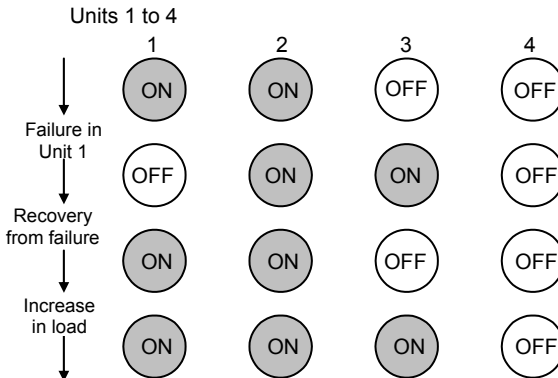

Figure 12. Operation examples: Operating units priority method

Sequence setting priority method (increase in load)



Sequence setting priority method (decrease in load)

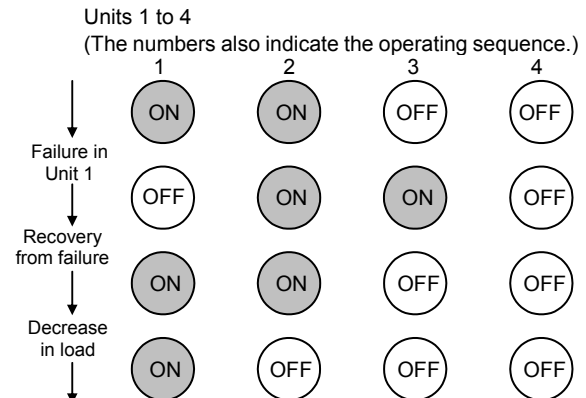

Figure 13. Operation examples: Sequence setting priority method



## 6. Sequence control at unit startup

The sequence control according to the unit start load shortens startup time for the group command ON.

The sequence control at unit startup forcibly applies to daytime/nighttime mode changeover so that the units can react to a sudden drop in load during overtime working hours.

When the group command ON is executed and nighttime mode is changed to daytime, actual load will be used if it is greater than the start load. When daytime mode is changed to nighttime, actual load will be used if it is smaller than the start load.

Note:

1. If the PARACONDUCTOR in connection adopts heating/cooling equipment operating sequence changeover, daytime (or nighttime) mode is always fixed. Sequence control at unit startup thus does not apply to daytime/nighttime mode changeover.
2. When operation is switched from daytime to nighttime mode, the larger of the start load (nighttime) and the actual load can be selected according to the settings.

Set the following 16 types of start load:

- Weekday, heating mode, daytime mode
- Weekday, heating mode, nighttime mode
- Weekday, cooling mode, daytime mode
- Weekday, cooling mode, nighttime mode
- Holiday, heating mode, daytime mode
- Holiday, heating mode, nighttime mode
- Holiday, cooling mode, daytime mode
- Holiday, cooling mode, nighttime mode
- Special day 1, heating mode, daytime mode
- Special day 1, heating mode, nighttime mode
- Special day 1, cooling mode, daytime mode
- Special day 1, cooling mode, nighttime mode
- Special day 2, heating mode, daytime mode
- Special day 2, heating mode, nighttime mode
- Special day 2, cooling mode, daytime mode
- Special day 2, cooling mode, nighttime mode

Note:

For the PARAMATRIX 4 with network connection, the settings of the weekdays, holidays, special days 1 and 2 settings follow the calendar setting of the connected upper system.

For the PARAMATRIX 4 without network connection, these settings follow the calendar setting of the OI. If the OI calendar is not set, or the OI is not used, the sequence control at unit startup is performed in accordance with the weekday start load settings.

## 7. Stabilizing control through effect waiting

To wait till the load become stabilized, the sequence control is disabled during a certain time period after increase or decrease in the units.

Effect waiting time for startup:

A period including the unit startup time (after startup) and the water round time is the effect waiting time after unit startup.

Effect waiting time for shutdown:

A period including the unit remain run time (after shutdown), the startup time of the rest of the units, and the water round time is the effect waiting time after unit shutdown.

## 8. Corrections of the number of units using temperature

For example in cooling mode, when the return water temperature at header side drops to or below a certain level for a certain period, the number of active units will be corrected (decreased). When the supply water temperature reaches to or over a certain level for a certain period, the number of active units will be corrected (increased).

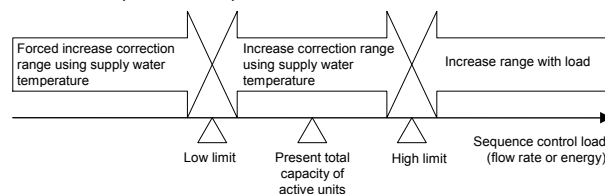

Figure 14. Corrections of the number of active units using temperature (example in cooling mode)

## 9. Maximum number of operating units setting

The maximum number of active (operating) units is set to secure standby units or to temporarily limit the number of active units. During the automatic operation or when the group command ON is executed, up to the predetermined maximum number of active units will run.

Set the following four types of the maximum number of active units:

- Heating mode, daytime mode
- Heating mode, nighttime mode
- Cooling mode, daytime mode
- Cooling mode, nighttime mode

## 10. Minimum number of operating units setting

During automatic operation or when the group command ON is executed, more than the minimum number of operating units will run.

Setting the minimum number to "0" stops the base unit when the load is low. The operating efficiency will thus be enhanced. (Applicable to dual pump system only)

## 11. Exclusion

A unit in the following conditions is excluded from the sequence control. However, an active unit excluded from the sequence control will be counted in the total of the capacities.

- Inactive due to power demand control
- Inactive due to power failure control
- Inactive due to fire control
- Inactive due to shutdown DI
- Inactive due to unit failure
- Inactive or active due to unmatched status.
- Inactive during the restart prevent time or the minimum shutdown time
- Operating sequence set to "0"  
(Operating sequence of the units are not assigned.)
- Capacity set to "0"

**Forced shutdown**

An individual unit is forcibly stopped by inputting the forced shutdown DI signal. The forced shutdown has priority over all the PARAMATRIX 4 start commands.

Note:  
Point type of the forced shutdown can be changed so that the forced shutdown is executed using the BMS client PC or the OI.

**Single-start**

Individual unit is started and stopped using the BMS client PC or using the OI. Single-start has priority over all the PARAMATRIX 4 start and stop commands except the forced shutdown.

When the group command ON is executed to the units in the automatic operation, the units will be operated in the sequence control. Even if the single-start is commanded to one of these units, the sequence control will return to the units operation after expiry of the effect waiting time.

Note:  
Single-start is disabled after the group command OFF is executed in the automatic operation.

**Restart prevent control**

For protecting the units, the units are controlled to reboot during restart prevent time (a certain period after the startup) and the minimum stop time (a certain period after the shutdown).

**Sequential start/stop control**

To prevent in-rush current simultaneous startup/shutdown of multiple units are disabled. When multiple units need to simultaneously start up or shut down, the units will start up or shut down at regular intervals sequentially in the registration order, not in the order of the operating sequence.

**Power demand control**

Power demand control commanded from the BMS client PC stops an individual unit. At this time, an alternate unit will not run so as not to increase power consumption. After the power demand control of all units is cancelled, normal sequence control will return.

**Failure control**

When a unit malfunctions and shuts down or when start/stop command to a unit is failed (the operation status does not agree with the output command in a certain period after the command), the unit is regarded as faulty and excluded from the sequence control. Then, the number of units to run will be recalculated to determine if an alternate unit needs to run. If an alternate unit is necessary, it will start up even while it is in the effect waiting time. Shutdown command will not be output to the faulty unit.

There are two ways to rest failure.

Manual reset:  
After removing the faulty factor from the unit, stop the unit using the BMS client PC or using the OI. Actual operating status and the command will thus agree, and the unit will return to normal operation.

Automatic reset:  
With the failure auto reset time, the PARAMATRIX 4 will automatically shut down when the time is expired. If the faulty DI input is cancelled, actual operating status and the command will thus agree, and the unit will return to normal operation.

**Pressure control (with bypass valve for single pump system only)**

Bypass valve is PID controlled so that the differential pressure between the headers maintains the constant level. Before executing the group command ON or increasing the units to run, the bypass valve is forcibly opened to a certain position to prevent sudden pressure rise.

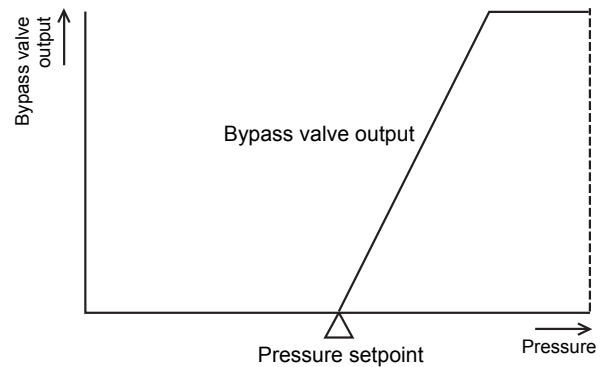

Figure 15. Pressure control with bypass valve

## Power failure restoration control

### 1. Detection of power failure status

#### Models with network connection:

Detects power failure by receiving power failure status from the BMS or power supply status DI of the target unit (OFF: supplying power, ON: power failure).

#### Models without network connection:

Detects power failure by receiving power supply status DI of the target unit.

### 2. Operation when power is restored

Automatic /manual changeover	PMX-4 power failure	Unit power failure	Power failure time*	Operation
Automatic	Yes	Yes	Within preset time	Sequence control according to the actual load or the start load before power failure, which is greater than the other. (Restart prevent for shutdown units due to power failure)
			Preset time or longer	Sequence control according to the start load (Restart prevent for shutdown units due to power failure)
	No	No	Within preset time	Sequence control according to the actual load or the start load before power failure, which is greater than the other
			Preset time or longer	Sequence control according to the actual load or the start load after power failure restoration, which is greater than the other
No	Yes	—	Sequence control according to the start load (Restart prevent for shutdown units due to power failure)	
Manual	Yes	Yes	—	Shutdown of all the units
		No	—	Operation continued from the last operation before power failure
	No	Yes	—	Shutdown of all the units

\* Power failure time is set at the parameter "panel brownout detection time." (Max.: 120 seconds)

#### Notes:

- \* Since the unit power supply is supposed to be mains-powered only or mains-powered with private power generation, power failure does not normally occur only at the PARAMATRIX 4. However, power failure only at PARAMATRIX 4 is described in the table in a case that control panel power is turned off for maintenance, etc.
- \* The unit power failure in the table indicates power failure at all the units. When unit power is turned off for maintenance without changing to manual operation, the units will be operated according to the failure control.
- \* Because the unit shutdown due to power failure is not controlled by the sequence control, stabilizing control through effect waiting will not be executed after the shutdown.
- \* The operations when manual/automatic operation is switched before/after power failure are not described in the above table.

## Operating diagnostics

Each operating diagnostic data is displayed on the optional OI.

- Totalized value  
Totalized flow rate and energy, accumulated runtime, and total ON/OFF count of units are displayed.
- Alarm record of operating status changes  
Annunciation history of dates and causes of up to 360 past operations, status changes and alarm are stored and displayed. (Note that the data cannot be exported.)
- Trend graph  
Trend graph of analog data is displayed on the OI. Up to past 288 data is stored at every 10 minutes and the maximum of 4 points per chart and the maximum of 8 charts are displayed. (Note that the data cannot be exported.)

## Network connection (with the upper system/sub-system)

Models with network connection communicate the following data besides input and output commands explained before.

- Various setpoints (supply water temperature, unit capacity setting, etc.)
- Various totalized values (flow rate, energy, run time, ON/OFF count, etc.)
- Various modes (cooling/heating changeover, daytime/nighttime changeover, etc.)
- Various alarms (remote unit error, analog high/low limit, deviation value alarm)
- Time, date, days of the week, time schedule

## Display Function (on the Optional OI)

The optional OI enables various displays and settings. See **PARAMATRIX 4 Operation Manual (AB-7114)** for details. The following describes the overview of screen hierarchy. Note that screen configurations vary depending on the model.

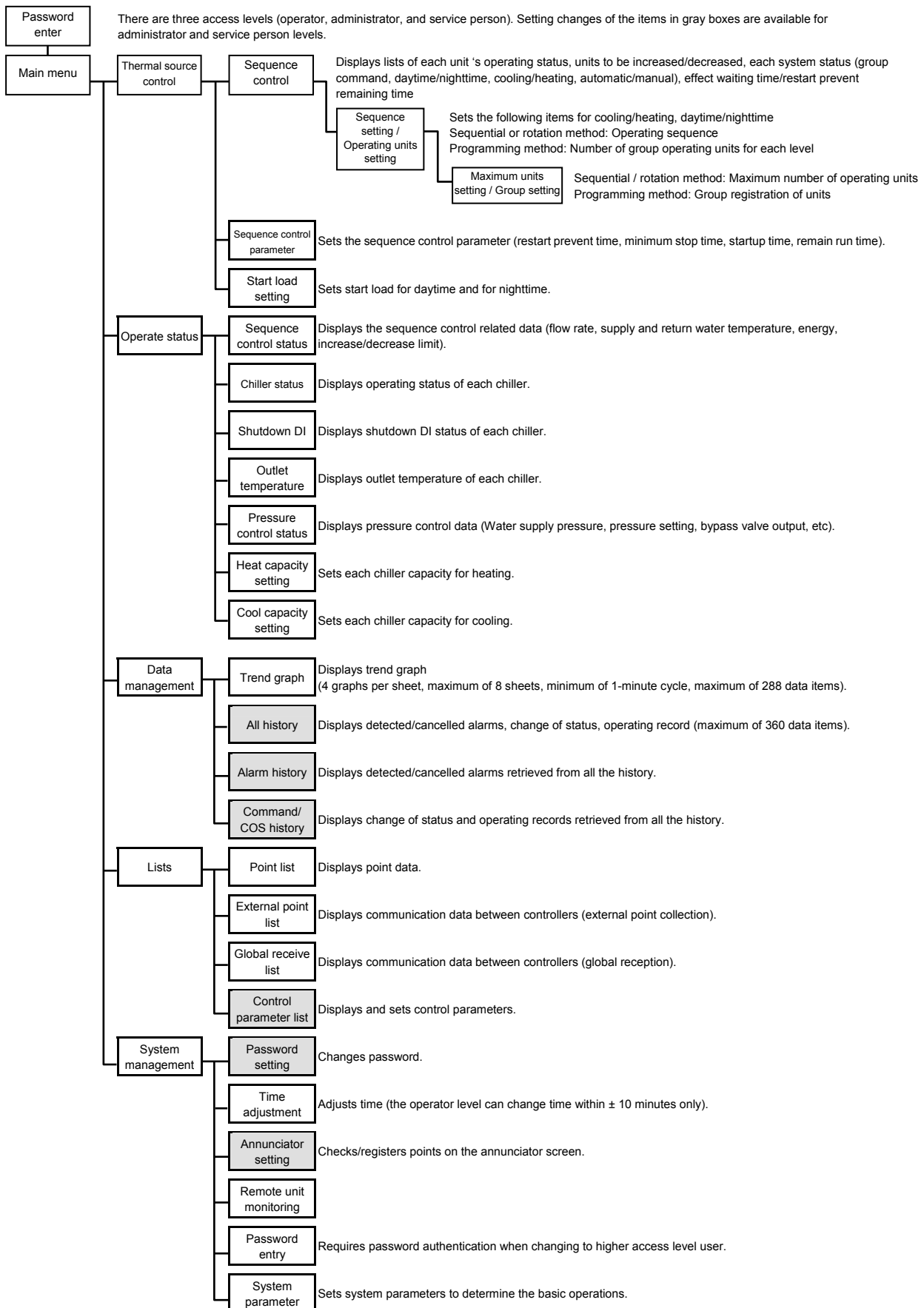

**Service Parts**

Part to replace	Replacement period	Note
Battery (of the basic module, of the optional OI)	5 years	
LCD of the optional OI	4 years or more	Replace the LCD when its brightness lowers and the LCD becomes less visible.
Touch panel of the optional OI	1,000,000 touch operations	Replace the touch panel when the touch panel sensitivity lowers or the touch panel cracks or become scratched.

**Related Documents**

For installation and wiring, refer to **PARAMATRIX 4 Installation Manual (AB-7117)**.

For operation and maintenance, refer to **PARAMATRIX 4 Operation Manual (AB-7114)**.

This blank page is added for page layout purposes.

This blank page is added for page layout purposes.

ACTIVAL, Infilex, PARAMATRIX, and savic-net are trademarks of Azbil Corporation in Japan or in other countries.  
KPEV is a registered trademark of Furukawa Electric Co., Ltd. in Japan.  
Microsoft and Windows are either registered trademarks or trademarks of Microsoft Corporation in the United States and/or other countries.



*Specifications are subject to change without notice.*

---

**Azbil Corporation**  
**Building Systems Company**

**<http://www.azbil.com/>**