

ACTIVAL™

Motorized Two-Way Valve with Flanged-End Connection <4-20 mA DC Input with 4-20 mA DC Feedback Output> (JIS 10K-FC200, -SCS13A)

General

ACTIVAL Model VY519XJ is a series of motorized two-way valves with flanged-end connection. The valve and actuator are integrated in a single unit.

Valve size ranges from DN15 (1/2") to DN80 (3"), and valve body rating corresponds to JIS 10K.

The actuator has a reversible synchronous motor, which operates at a low voltage of 24 V AC.

4-20 mA DC input control signal provides proportional control in combination with a PLC (e.g., Model R35/R36).

* Notes

JIS: Japanese Industrial Standards

PLC: Programmable Logic Controller



Features

- Compact and lightweight:
Rotary motor actualizes small body and light weight.
- Valve and actuator integrated in a single unit:
Pre-assembled body requires no adjustment.
- Valve for water/steam control applicable to high differential pressure, large Cv value, high rangeability, and low leakage.
- Durable actuator with low power consumption.
- Equal percentage flow characteristics.
- 4-20 mA DC output available for position feedback.
- Open/close changeover for input signal failure:
Actuator fully opens/closes valve in case that the control signal is not input to the actuator. (Default: Fully open)
- Direction changeover of control action:
Open/close action by 4-20 mA DC input signal is reversely controllable.
Normal action 4 mA: 0 % to 20 mA: 100 %
Reverse action 20 mA: 0 % to 4 mA: 100 %.
(Default: Normal action)
- Adjustable dead band*:
Dead band width can be narrowed to more precisely operate valve actuator.

* Actuator is not operated by input signal changed less than a certain amount. This amount of change is called dead band.

IMPORTANT:

- The service life of ACTIVAL operated with small dead band can be shortened since the ACTIVAL operates more frequently with small dead band than with normal dead band.
- Use shielded cable for the ACTIVAL with small dead band. Noise may affect the signal transmission causing operation error, otherwise.
- To control ACTIVAL with a third-party controller, please consult with Azbil Corporation's sales personnel.



Safety Instructions

Please read instructions carefully and use the product as specified in this manual. Be sure to keep this manual near by for ready reference.





















Usage Restrictions

This product is targeted for general air conditioning. Do not use this product in a situation where human life may be affected. If this product is used in a clean room or a place where reliability or control accuracy is particularly required, please contact Azbil Corporation's sales representative. Azbil Corporation will not bear any responsibility for the results produced by the operators.

 **WARNING**

-  • This product weighs 18 kg or over (depending on the models). To prevent hazardous accident and severe injury, move or carry the product with enough manpower or using a vehicle.
-  • Do not disassemble the product. Disassembly may result in electrical shock or equipment damage.

 **CAUTION**

-  • Installation and wiring must be performed by qualified personnel in accordance with all applicable safety standards.
-  • Disconnect power from ACTIVAL before performing any wiring, maintenance (installation), and setting the selector switches to prevent equipment damage.
-  • All wiring must comply with local codes of indoor wiring and electric installation rules.
-  • Use crimp terminal lugs with insulation for electric wires to be connected to the screw terminals.
-  • Make sure all the wires are tightly connected to the screw terminals. Loose connection may cause fire or heat generation.
-  • Always close the top cover and the terminal cover except when setting the selector switches and connecting/disconnecting wires.
-  • Install the ACTIVAL in the position as specified in this manual. Excessively tight connection of the valve to a pipe and improper installation position may cause valve damage.
-  • Do not install the ACTIVAL in a location close to a steam coil or a hot-water coil. High temperature radiation may result in an actuator malfunction.
-  • After installation, make sure no fluid leaks from the connecting parts of valve and pipes. Incorrect piping may cause fluid leakage.
-  • Do not allow any foreign substance inside the piping. Flush the piping so that no foreign substance remains. Attach a strainer with 40 or more meshes (80 or more meshes recommended for steam control) in a pipe on the inflow side of the ACTIVAL to prevent equipment damage.
-  • This product must be operated within its rated operating ranges specified in this manual. Failure to comply will cause equipment damage.
-  • This product must be operated under the operating conditions (power, temperature, humidity, vibration, shock, installation position, atmospheric condition, etc) specified in this manual to prevent equipment damage.
-  • Avoid using the ACTIVAL (actuator, valve, and other components) in a corrosive gas including oxide gas and explosive gas.
-  • Set the selector switches using a pen nib or fingers. Do not use a tool such as a screwdriver. Such a tool can damage the selector switches or the PCB.
-  • To operate the ACTIVAL with small dead band, provide shielded cable for input/output signal lines and power line. Unshielded cable can cause error due to noise.
-  • Operate the ACTIVAL within the service life, and avoid application that keeps product operating cycle excessively frequent so as not to shorten its service life.
-  • Do not leave the controlled fluid frozen to prevent equipment damage or fluid leakage.
-  • Do not put heavy load on the actuator.
-  • Avoid touching the installed ACTIVAL (valve body, yoke, joint). When being used to control hot water, it reaches high temperature and may cause burn injury.
-  • Dispose of this product as an industrial waste in accordance with your local regulations. Do not reuse all or part of this product.

Model Numbers

Model VY519XJ00XX is the model for the valve and actuator integrated into a single unit.

The model number label is attached to the yoke. The 4-20 mA control signal is indicated on the actuator label and on the wiring diagram.

Base model number	Actuator/valve		Actuator		Valve	Description
	Control signal	Rating/material	Type	—	Nominal size/Cv	
VY51	9					Motorized two-way valve with flanged-end connection
						4 mA DC to 20 mA DC input with 4 mA DC to 20 mA DC feedback output
		0				JIS 10K / JIS FC200 [for chilled/hot water, high temperature water]
		1				JIS 10K / JIS SCS13A [for chilled/hot water, high temperature water]
		5				JIS 10K / JIS FC200 [for 0 °C to 175 °C steam]
		6				JIS 10K / JIS SCS13A [for 0 °C to 175 °C steam]
				J		IEC IP54 protected and standard torque type actuator with terminal block (Mountable valve sizes: DN15 to DN80)
					00	—
						11 DN15 (1/2") / 1.0 in Cv value
						12 DN15 (1/2") / 2.5 in Cv value
						13 DN15 (1/2") / 6.0 in Cv value
						14 DN15 (1/2") / 1.6 in Cv value
						15 DN15 (1/2") / 4.0 in Cv value
						21 DN25 (1") / 10 in Cv value
						22 DN25 (1") / 16 in Cv value
						41 DN40 (1 1/2") / 25 in Cv value
					42 DN40 (1 1/2") / 40 in Cv value	
					51 DN50 (2") / 65 in Cv value	
					61 DN65 (2 1/2") / 95 in Cv value	
					81 DN80 (3") / 125 in Cv value	

Specifications

For weight, refer to the table shown in the section **Dimensions**.

Valve specifications

Item	Specification			
Model	Two-way valve with flanged-end connection			
Body pressure rating	JIS 10K (Max. pressure: 1.0 MPa)			
Size, Cv, Close-off ratings	Model number	Nominal size	Cv	Close-off ratings
	VY519XJ0011	DN15 (1/2")	1.0	1.0 MPa
	VY519XJ0012	DN15 (1/2")	2.5	1.0 MPa
	VY519XJ0013	DN15 (1/2")	6.0	1.0 MPa
	VY519XJ0014	DN15 (1/2")	1.6	1.0 MPa
	VY519XJ0015	DN15 (1/2")	4.0	1.0 MPa
	VY519XJ0021	DN25 (1")	10	1.0 MPa
	VY519XJ0022	DN25 (1")	16	1.0 MPa
	VY519XJ0041	DN40 (1 1/2")	25	1.0 MPa
	VY519XJ0042	DN40 (1 1/2")	40	1.0 MPa
	VY519XJ0051	DN50 (2")	65	1.0 MPa
	VY519XJ0061	DN65 (2 1/2")	95	1.0 MPa
	VY519XJ0081	DN80 (3")	125	0.7 MPa
Materials	Body	Gray cast iron (JIS FC200) for flat face (FF) type Stainless steel (JIS SCS13A) for raised face (RF) type		
	Plug and stem	Stainless steel (equivalent to JIS SCS)		
	Seat ring	Inorganic fiber		
	Gland packing	Inorganic fiber		
	Gasket	Non-asbestos joint sheet		
End connection	Flanged-end connection Models VY5190J, VY5195J (JIS FC200): Flat face (FF) Models VY5191J, VY5196J (JIS SCS13A): Large raised face (RF)			
Allowable fluid temperature*	Models VY5190J, VY5191J: 0 °C to 175 °C chilled/hot water, high temperature water Models VY5195J, VY5196J: 0 °C to 175 °C steam			
Flow characteristics	Equal percentage			
Rangeability	100 : 1			
Seat leakage	0.01 % or less of rated Cv value (0.0006 Cv or less for DN15 model)			
Paint	Body of FF type (JIS FC200): Gray Body of RF type (JIS SCS13A): Unpainted			
Applicable fluid	Chilled/hot water, high temperature water, steam, brine (ethylene glycol solutions, 50 % max)			
Installation orientation	Installable in any position ranging from upright to sideways (90° tilted) *Always install in upright position outdoors.			
Actuator to be combined	Integrated with the valve			
Valve position indication	with the groove on the top of the valve stem			

* Note: To use the stainless steel valve for fluid of temperature below 0 °C, consult with our sales personnel.

Actuator specifications

(1/2)

Item	Specification
Power supply	24 V AC \pm 15 %, 50 Hz/60 Hz
Applicable valve size	DN15 to DN80 of standard torque type
Power consumption	12 VA
Timing	63 \pm 5 sec (50 Hz) / 53 \pm 5 sec (60 Hz)
Control signal input	4 mA DC to 20 mA DC input (Input impedance: 100 Ω)
Feedback signal output	Range: 4 mA DC (0 % position) to 20 mA DC (100 % position) Max. load resistance: 500 Ω

Item	Specification		
Environmental conditions		Rated operating conditions	Transport storage conditions*2
	Ambient temperature*1	-20 °C to 50 °C (Fluid temperature 0 °C to 150 °C)	-20 °C to 70 °C
		-20 °C to 45 °C (Fluid temperature 150 °C to 175 °C)	
	Ambient humidity	5 %RH to 95 %RH	
	Vibration	4.9 m/s ² (10 Hz to 150 Hz)	19.6 m/s ² (10 Hz to 150 Hz)
Notes: *1 Do not allow the fluid to freeze. *2 The actuator shall be packed during transport.			
Materials	Case	Aluminum alloy casting	
	Top cover, terminal cover	Plastic (polycarbonate resin) (Color: gray)	
	Yoke	Steel plate	
Surface finishing	Case	None	
	Yoke	Electro-galvanizing (Bright chromate finish)	
Installation locations	Indoor / outdoor (keep away from direct sunlight.)		
Valve position indication	Pointer located at the bottom of the actuator shows the position by pointing at the value of the scale (0: close to 100: open) on front, rear, and bottom sides.		
Manual operation	Available. Refer to the section Manually opening/closing the ACTIVAL .		
Wires connection	M3.5 screw terminal connection		
Enclosure rating	IEC IP54 (dust-proof and splash-proof)		
Insulation resistance	Between terminal and case: 5 MΩ or higher at 500 V DC		
Dielectric strength	Between terminal and case: 500 V AC/min with 5 mA or less leakage current		
Installation orientation	Installable in any position ranging from upright to sideways (90° tilted) *Always install in upright position outdoors.		
Position for shipment	100 % (fully open)		

Options

For options, separate order is required.

Item	Specification			
Seal connector (Part No. 83104346-003)	Applicable wire size: φ7 mm to φ9 mm (Seal connector is necessary for IEC IP54 protection.)			
Auxiliary switches*1 (Part No. 83165274-001)	Number of auxiliary switches: 2 (SW A and SW B) Maximum applied voltage/current: 30 V DC / 3 A DC Actuating position SW A: Adjustable between 0 % (fully closed) to 100 % (fully open) SW B: Adjustable between 0 % (fully closed) to 100 % (fully open)			
Auxiliary potentiometer*1 (Part No. 83165275-001)	Number of auxiliary potentiometer: 1 Total resistance: Nominal 1 kΩ Operating position: 0 % (fully closed) to 100 % (fully open) Max. applied voltage: 5 V DC			
Valve flange adapter kit (for replacing Model V5063/V5064 with Model VY51XX)	Hot-rolled steel (JIS*2 SS400), electro-galvanized/not electro-galvanized			
		Electro-galvanized	Not electro-galvanized	Applicable valve size
	Part No. 83168456-001	Part No. 83168456-101	DN15	
	Part No. 83168456-002	Part No. 83168456-102	DN25	
	Part No. 83168456-003	Part No. 83168456-103	DN40	
	Part No. 83168456-004	Part No. 83168456-104	DN50	
	Part No. 83168456-005	Part No. 83168456-105	DN65	
Part No. 83168456-006	Part No. 83168456-106	DN80		

Notes:

*1 Either of an auxiliary switch or an auxiliary potentiometer can be added, but not both.

*2 JIS: Japanese Industrial Standards

CE Marking Conformity

This product complies with the following Electromagnetic Compatibility (EMC).

EMC : EN61000-6-2, EN55011 Class A

Dimensions

Model VY5190J/VY5195J (JIS FC200 valve)

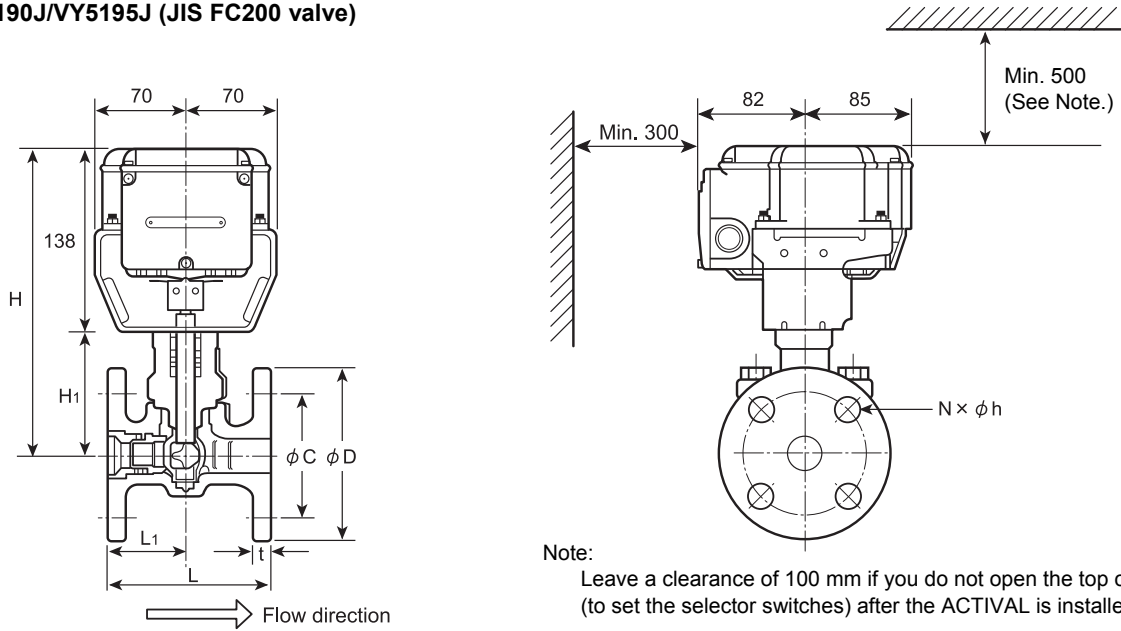

Note:
Leave a clearance of 100 mm if you do not open the top cover (to set the selector switches) after the ACTIVAL is installed.

Valve size (DN)	H	H ₁	L	L ₁	t	φC	φD	φh	N	Weight (kg)
15	213	75	108	50	16	70	95	15	4	4.6
25	228	90	127	60	18	90	125	19	4	6.6
40	241	103	165	82.5	20	105	140	19	4	10
50	245	107	178	89	20	120	155	19	4	11.5
65	262	124	190	90	22	140	175	19	4	16
80	263	125	203	100	22	150	185	19	8	18.5

Figure 1. Dimensions and maintenance clearance (mm): Model VY5190J/VY5195J

Model VY5191J/VY5196J (JIS SCS13A valve)

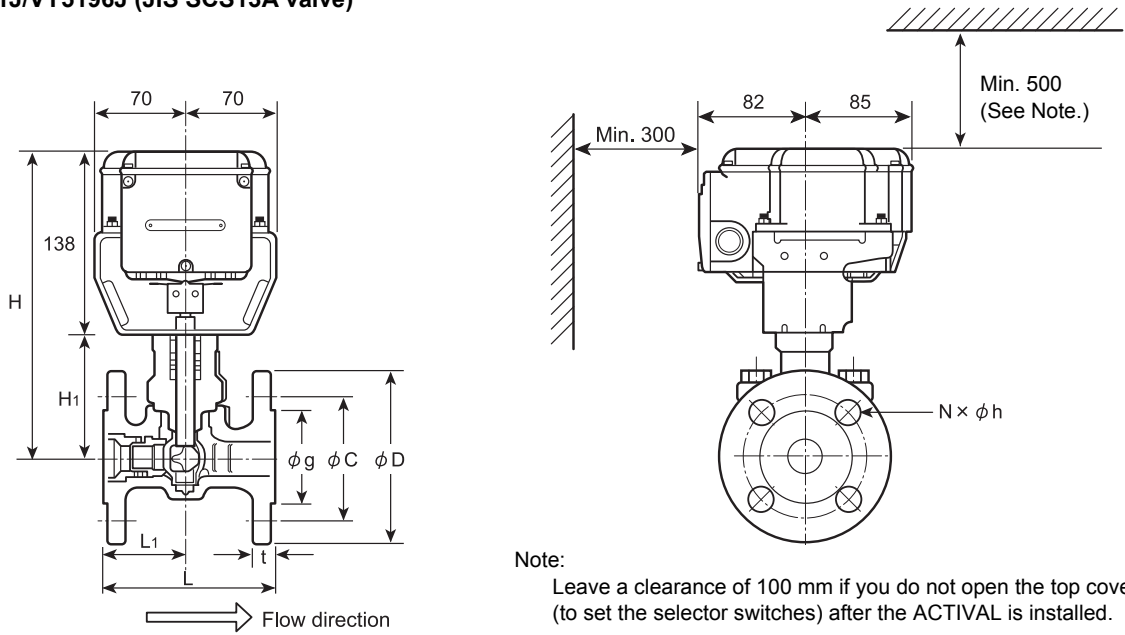

Valve size (DN)	H	H ₁	L	L ₁	t	φg	φC	φD	φh	N	Weight (kg)
15	213	75	108	50	12	51	70	95	15	4	4.6
25	228	90	127	60	14	67	90	125	19	4	6.6
40	241	103	165	82.5	20	81	105	140	19	4	10
50	245	107	178	89	20	96	120	155	19	4	11.5
65	262	124	190	90	22	116	140	175	19	4	16
80	263	125	203	100	22	126	150	185	19	8	18.5

Figure 2. Dimensions and maintenance clearance (mm): Model VY5191J/VY5196J

Parts Identification

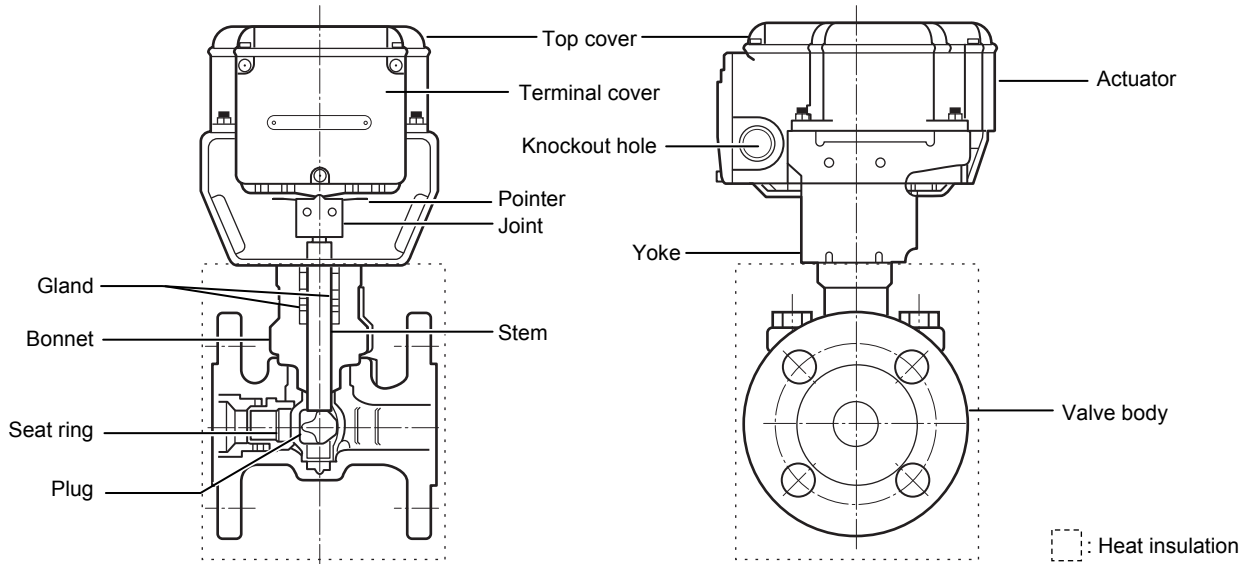

Figure 3. Parts identification

Setting

On the PCB (printed circuit board) of the actuator, the selector switches are provided.

CAUTION	
	• Disconnect power from ACTIVAL before performing any wiring, maintenance (installation), and setting the selector switches to prevent equipment damages.
	• Set the selector switches using a pen nib or fingers. Do not use a tool such as a screwdriver. Such a tool can damage the selector switches or the PCB.
	• Always close the top cover and the terminal cover except when setting the selector switches and connecting/disconnecting wires.
	• To operate the ACTIVAL with small dead band, provide shielded cable for input/output signal lines and the power line. Unshielded cable can cause error due to noise.

<p>IMPORTANT:</p> <p>The service life of ACTIVAL operated with small dead band can be shortened since the ACTIVAL operates more frequently with small dead band than with normal dead band.</p>
--

Identification of the selector switches

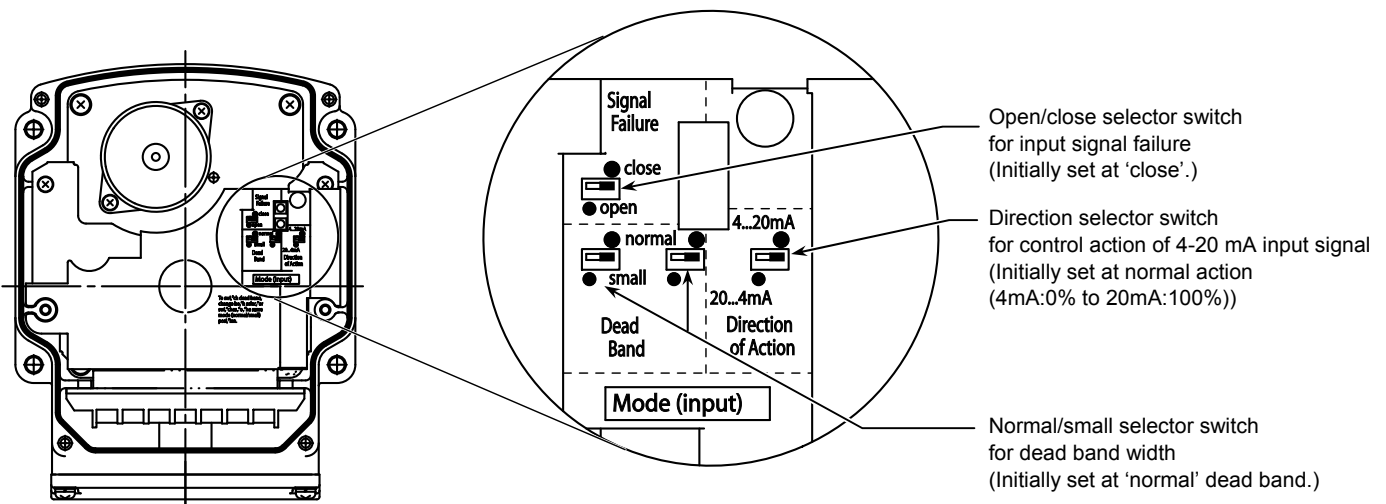

Figure 4. Selector switches

Open/close selector switch for input signal failure:

If no control signal is input, the actuator automatically closes (0 %) or opens (100 %) the valve by setting the selector switch at 'open' (100 %) or 'close' (0 %).

Direction selector switch for control action of 4-20 mA input signal:

Direction of control action by 4-20 mA DC input signal can be reversely switched.

Normal action: 4 mA for 0 % to 20 mA for 100 %

Reverse action: 20 mA for 0 % to 4 mA for 100 %

Normal/small selector switch for dead band width:

To more precisely operate the valve, smaller dead band (than the normal) of the control signal input can be set. Two selector switches are provided for the normal/small dead band width. Always set the both switches at the same mode ('normal' or 'small').

Installation

Precautions for installation

⚠ CAUTION

- ❗ • Disconnect power from ACTIVAL before performing any wiring, maintenance (installation), and setting the selector switches to prevent equipment damage.
- ❗ • Install the ACTIVAL in the position as specified in this manual. Excessively tight connection of piping and improper installation position may damage the valve.
- ❗ • After piping installation, make sure no fluid leaks from the connecting parts. Incorrect piping may cause fluid leakage.
- ❗ • Do not allow any foreign substance inside the piping. Flush the piping so that no foreign substance remains. Foreign substance may damage the valve.

- ACTIVAL Model VY519XJ is the valve and actuator integrated into a single unit. Do not combine the valve with any other actuator, or do not combine the actuator with any other valve.
- To remove foreign substances inside the pipes, install a strainer with 40 or more meshes (80 or more meshes recommended for a steam control) on the inflow side of each valve. In case that the strainers cannot be installed on the inflow side of each valve, install it on the pipe diverting sections (sections diverting from main piping system to sub piping system).
- Install the valve so that the flow direction of process fluid agrees with the arrow indicated on the valve body.

Installation location

⚠ CAUTION

- ❗ • Avoid using the ACTIVAL in an atmosphere containing oxidizing or explosive gas since it may corrode the actuator, valve, or their components.
- ❗ • The actuator may malfunction if being exposed to high heat radiation. Do not install it near by steam coil or hot water (in high temperature) coil.

IMPORTANT:

- The covers might be corroded by some chemical and organic solvent/vapor. Do not clean the ACTIVAL using such substances, or do not expose the ACTIVAL to such substances.
 - When the ACTIVAL is used for steam humidifying, install a valve interlocking with air-conditioning unit on the inflow side in case the ACTIVAL gets damaged.
 - Although the ACTIVAL can be used in high humidity environments (max. 95 %RH), do not immerse the actuator in water.
 - Although the ACTIVAL can also be used outdoors, be sure not to expose the ACTIVAL to direct sunlight.
- Install the ACTIVAL in a position allowing easy access for maintenance and inspection. Figs. 1 and 2 show the minimum clearance for maintenance and inspection. When installing the ACTIVAL in a ceiling space, provide an access hole within the 50 cm radius of the ACTIVAL. And, place a drain pan under the valve.
 - Do not mount the ACTIVAL on a pipe where water hammer occurs, or where solid objects including slug may accumulate.
 - To set the selector switches after installation, leave a enough clearance above the top cover of the actuator, as shown in Figs. 1 and 2.

Mounting position

The ACTIVAL can be mounted in any position ranging from upright to sideways (90° tilted). The ACTIVAL should be installed with its actuator vertically positioned above the valve body. (See Fig. 5.) However, the ACTIVAL must be installed always in upright position outdoors.

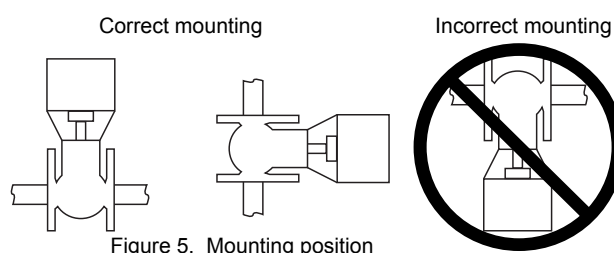

Figure 5. Mounting position

Piping

- Check that the model number of the product is what you ordered. The model number is shown on the label attached to the yoke.
- Install a bypass pipe and gate valves on the inflow, outflow, and bypass sides. Also, install a strainer on the inflow side.
- When installing the ACTIVAL to the pipes, do not allow any object, such as chips, to get inside a pipe or valve. Valve cannot fully closes, or the valve seat may get damaged causing fluid leakage, due to an object jammed inside the valve.
- When piping, do not apply too much sealing material, such as solidifying liquid and tape, to the pipe connection sections so that these materials flow into the valve. Valve cannot fully closes, or the valve seat may get damaged causing fluid leakage, due to the sealing material jammed inside the valve.
- Before activating the ACTIVAL, flush the pipes (with the ACTIVAL installed) at the maximum flow rate to remove all the foreign substances. Fully open (100 % position) the ACTIVAL to flush. (Factory preset position: 100 %)
- For steam control, drain retained water (condensate) in piping. Install a trap on a pipe run which may retain condensate. Condensate may cause water hummer or damage the valve and piping.

Heat insulation

Do not apply heat insulation to the actuator or to the yoke, as [] shows in Fig. 3. If the yoke and the actuator are covered with insulation material, the pointer cannot be checked and may be distorted.

Factory preset position

The actuator shaft is positioned at 100% (in fully open position) for shipment. The shaft is thus completely turned clockwise, and the pointer points at '100'. (See Fig. 6.)

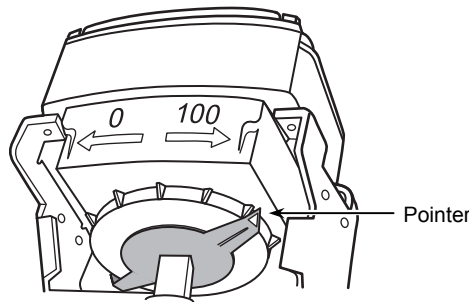

Figure 6. Pointer position for shipment

Manually opening/closing the ACTIVAL

IMPORTANT:

- Manually opening/closing the ACTIVAL with the power (24 V AC) applied may damage the actuator.
- To manually open/close the ACTIVAL, do not turn the joint beyond the fully open (100)/closed (0) mark.
- To manually open/close the ACTIVAL, slowly turn the joint. If shock is sent to the actuator, the actuator may get damaged.

Disconnect the power from the ACTIVAL before manually operating the ACTIVAL. As shown in Fig. 7, from the front of the ACTIVAL, hold the joint using a tool such as a wrench, and turn the joint slowly toward the set position.

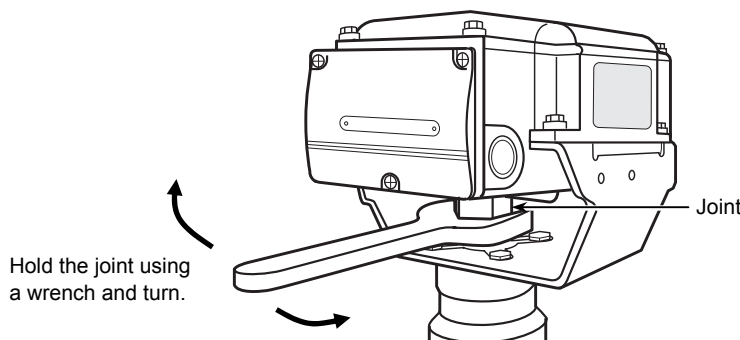

Figure 7. Manual operation

Auxiliary switch / Auxiliary potentiometer (optional)**IMPORTANT:**

- The auxiliary switch/potentiometer is installed on site. Refer to the instructions supplied with the auxiliary switch/potentiometer for installation.
- Do not open the top cover except when adjusting the auxiliary switch/potentiometer. Close the top cover instantly after adjusting the auxiliary switch/potentiometer.
- Do not put any load on the top cover.

Procedure to change the actuator mounting position**IMPORTANT:**

- Do not change the combination of the valve, yoke, and actuator.
- Set the ACTIVAL in 100 % position when changing the mounting position. If the valve in 0 % position is assembled with the actuator in 100 % position, the actuator put torque on the closed valve, and the gear of the actuator gets damaged.

- 1) Remove the screws connecting the actuator and the yoke. Lift the actuator and detach it from the yoke. Make sure that the groove on the top of the valve stem is parallel to the pipes (indicating the valve in 100 % position). <Step 1 in Fig. 8>
- 2) Remove the screws connecting the yoke and the valve. <Step 2 in Fig. 8>
- 3) Change the facing direction of the yoke. The yoke and actuator can be horizontally rotated every 90° (0°/90°/180°/270° from the factory preset position) to mount onto the valve.
- 4) A thermal insulation sheet is inserted between the yoke and the valve. When changing the mounting positions, reinsert the sheet and then fit the yoke into the new mounting position.
- 5) Before fixing the yoke to the valve with the screws, check that the actuator engages correctly with the valve stem (at the new mounting position). Check that the pointer of the actuator indicates 100 % position as well. Then, fix the yoke to the valve. <Step 3 in Fig. 8>
- 6) Mount the actuator. Place the actuator, with its facing direction changed, on the yoke, and fix them with the screws. <Step 4 in Fig. 8>
- 7) Check that the ACTIVAL with the mounting position changed operates smoothly (from 0 % to 100 %).

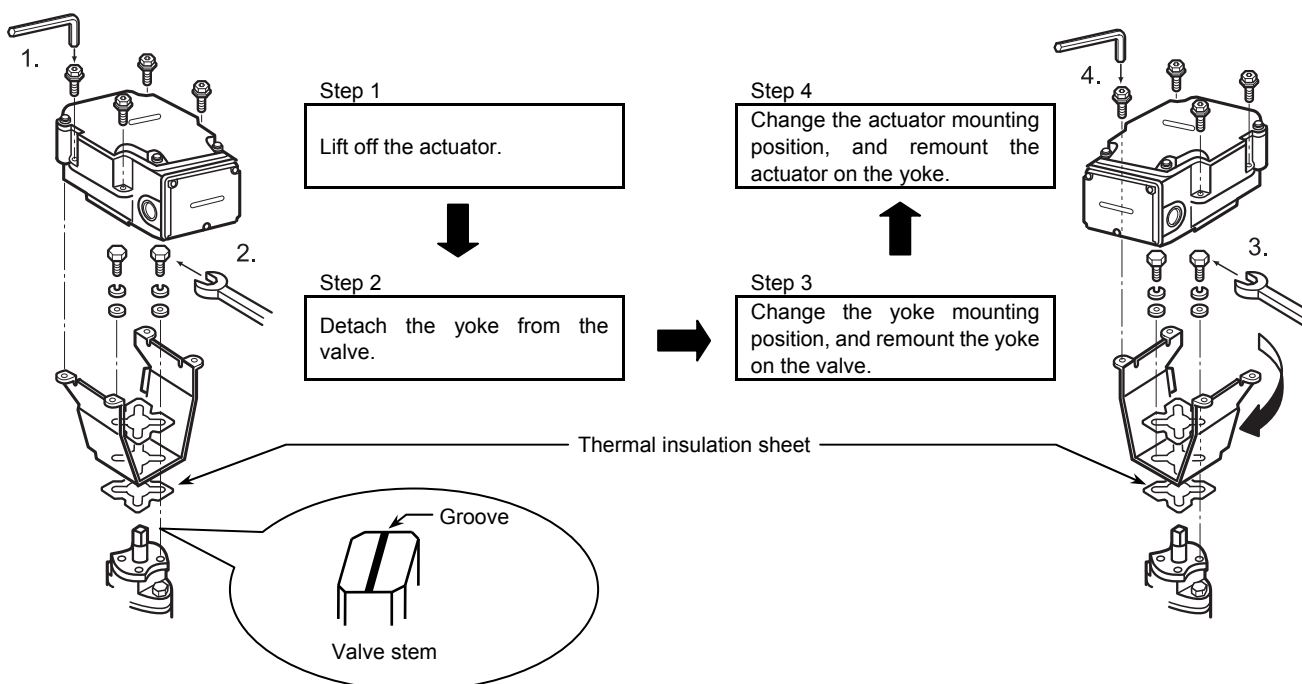

Figure 8. Changing the actuator mounting position

Wiring

⚠ CAUTION	
!	• Disconnect power from ACTIVAL before performing any wiring or maintenance (installation), and setting the selector switches to prevent equipment damage.
!	• Always close the top cover and the terminal cover except when setting the selector switches and connecting/disconnecting wires.

IMPORTANT:	
• The ACTIVAL is designed for 24 V AC power supply voltage. Do not apply any other power voltage (e.g., 100 V AC, 200 V AC) to the ACTIVAL.	
• Make sure the polarity of the power supply and 4-20 mA DC feedback output referring to the wiring diagrams. Incorrect wiring may result in PCB (print circuit board) burnout.	
• To prevent damage, cover the terminals except when connecting/disconnecting wires.	
• Do not connect 24 V AC power to the terminals 4 to 7.	

Wiring precautions

- 1) To lead the wires into the terminals, cut out a knockout hole for a wiring port. Two knockout holes are provided on the bilateral sides of the actuator terminals. Select a knockout hole according to the conduit mounting direction, and cut it out by lightly knocking the hole using a screwdriver.

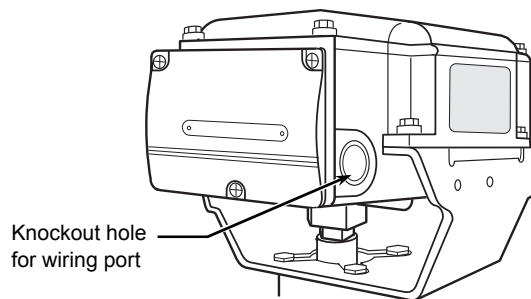

Figure 9. Knockout hole for wiring port

- 2) Unscrew the 3 setscrews (M4 × 10) of the terminal cover and remove the terminal cover, as shown in Fig. 10.

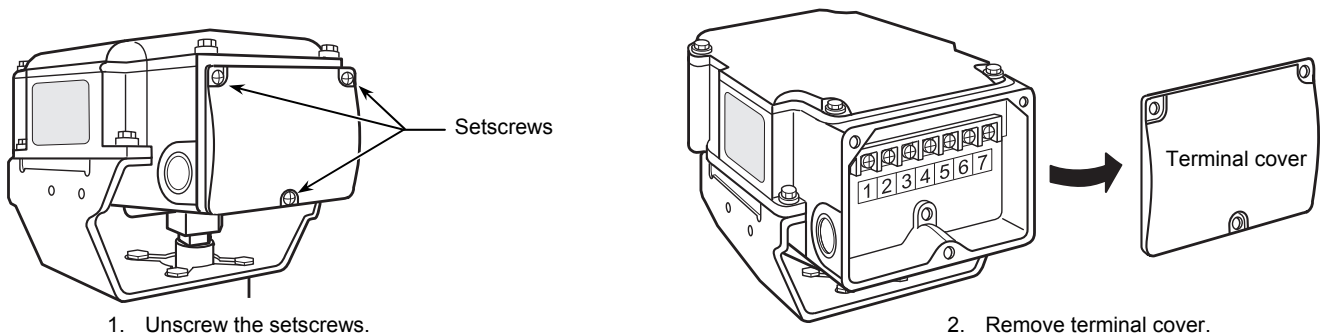

Figure 10. Terminal cover removal

- 3) Correctly connect the wires to the terminals with M3.5 screw terminal lugs, referring to Figs 11 to 13.
- 4) When the ACTIVAL is used in a high-humidity environment or outdoors, use a water-proof connector for the wiring port.

To keep IP54 protection (dust-proof and splash-proof),

Use a water-proof connector for the ACTIVAL in a high-humidity environment or outdoor location.

- Be sure to completely close the terminal cover and the top cover.
- Waterproof the wiring port.
 - For cable connection, use a water-proof connector. (Seal connector Part No. 83104346-003 is recommended.)
 - For conduit connection, use a water-proof plica tube or the like.

Terminals connection

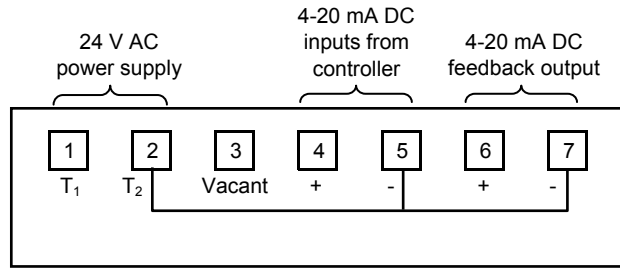
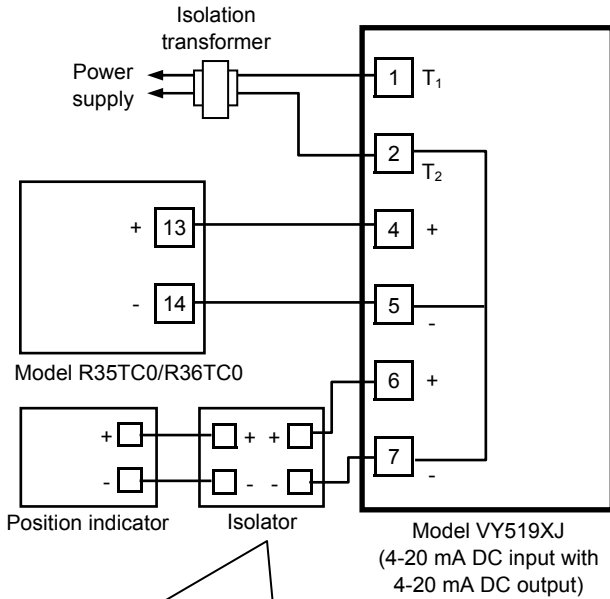

Figure 11. Terminals connection of Model VY519XJ00XX

Connection examples (Connection to Azbil Corporation's R series controller)

Connection to Model R35TC0/R36TC0



Isolation example:
If the position indicator is not isolated inside, provide an isolator. If isolated, an isolator is not required.

Figure 12. Connection example: Single Model VY519XJ00 with Model R35TC0/R36RC

Connection to Model R35TC0/R36TC0 (Parallel operation)

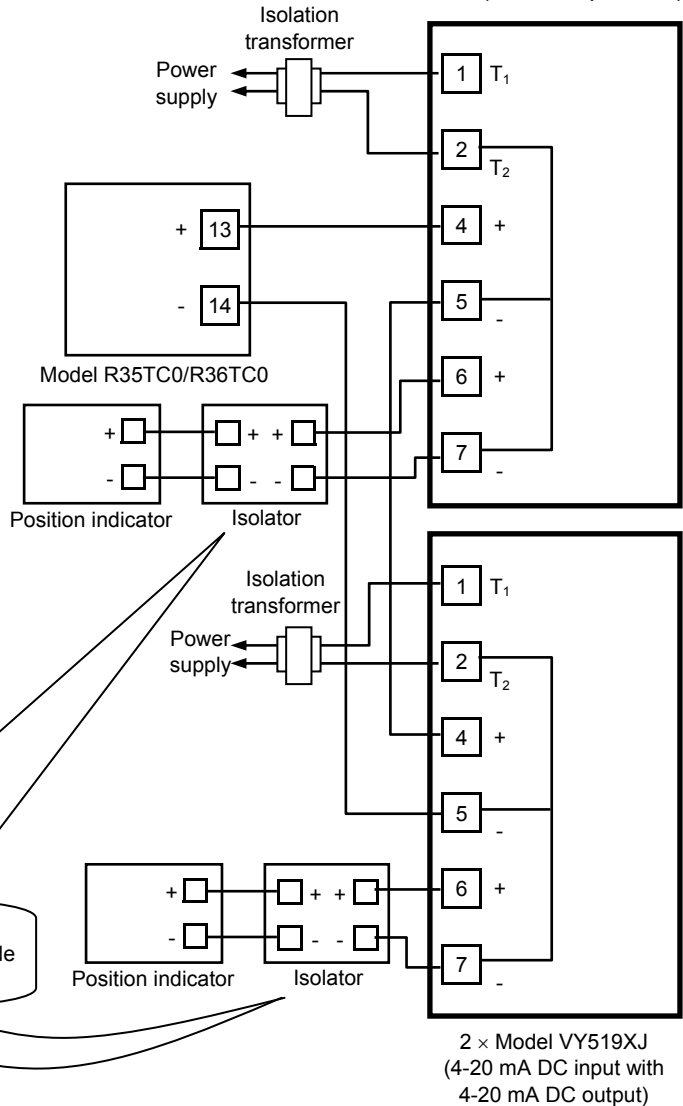

Isolation example:
If the position indicator is not isolated inside, provide an isolator. If isolated, an isolator is not required.

Figure 13. Connection example: Two Model VY519XJ with Model R35TC0/R36RC (Parallel operation)

Notes:

- * Input impedance of the actuator is 100 Ω.
- * For connecting multiple ACTIVAL to one controller (e.g., Model R35.36), provide a transformer (two in total) for each ACTIVAL since 4-20 mA input is not isolated from other terminals.
- * Terminals 2, 5, and 7 are connected inside the actuator. To connect to a device (PLC, position indicator, etc.) with its terminals not isolated inside, externally isolate (between the ACTIVAL and the device). Otherwise, a loop is formed for the common line and can damage the circuit of the ACTIVAL. (R series controllers including Model R35/R36 shown in Figs. 12 and 13 are isolated inside.)
- * Isolation transformer is required for ACTIVAL. Transformer without isolation may damage the ACTIVAL and other devices connected to ACTIVAL.

Internal Connection of Auxiliary Switch / Auxiliary Potentiometer

Auxiliary switch Part No. 83165274-001

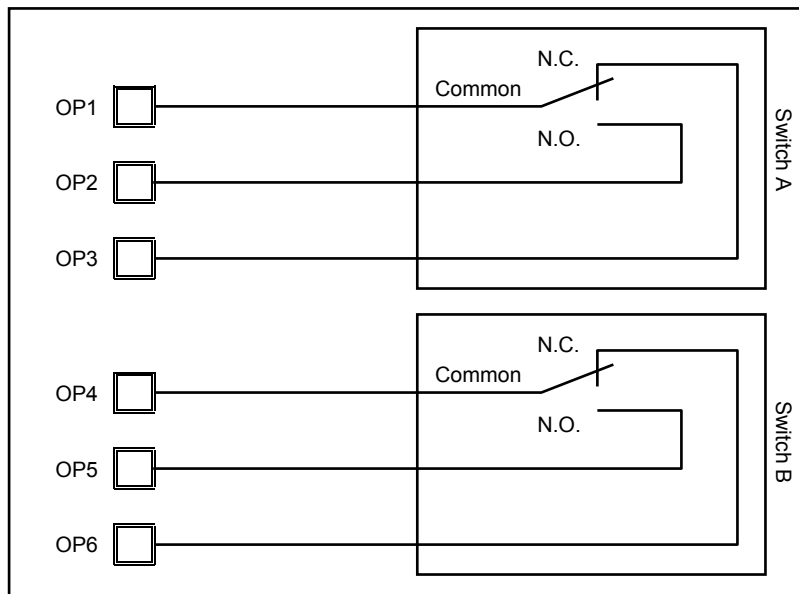

Switches A and B actuating position: Adjustable between 0 % (fully closed) and 100 % (fully open)

Figure 14. Internal connection of Part No. 83165274-001

Auxiliary potentiometer Part No. 83165275-001

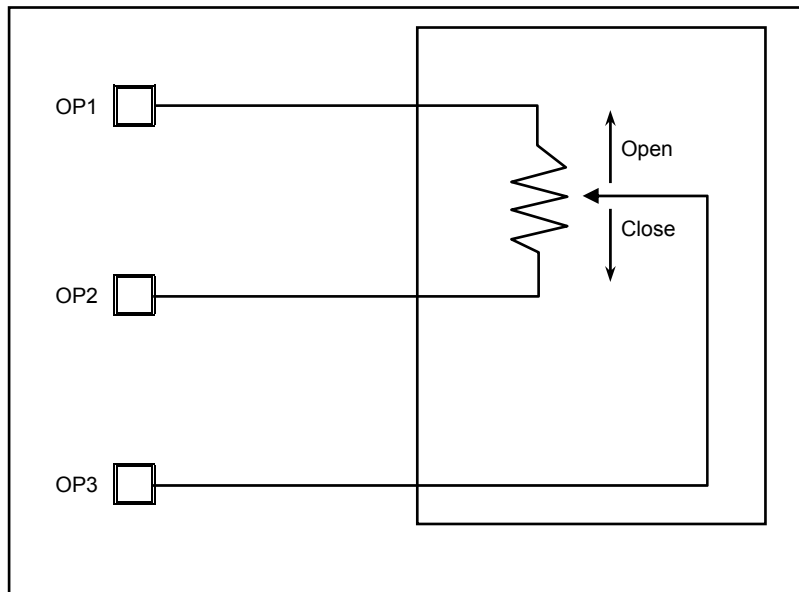

Potentiometer operating position: Adjustable between 0 % (fully closed) and 100 % (fully open)

Figure 15. Internal connection of Part No. 83165275-001

Inspection and Maintenance

CAUTION



- Avoid touching the installed ACTIVAL (valve body, yoke, joint). When being used to control hot water, it reaches high temperature and may cause burn injury.

- Inspect the ACTIVAL according to Table 1.
- Manually open/close the ACTIVAL at least once a month if it is left in inactive state for a long period.
- Visually inspect the fluid leakage of the valve and the actuator operations every six months. If any of the problems described in Table 2 are found, take corresponding actions shown in the table.
If your problem is not solved by the corresponding action, please contact Azbil Corporation near you.

Table 1. Inspection items and details

Inspection item	Inspection interval	Inspection detail
Visual inspection	Semiannual	<ul style="list-style-type: none"> • Fluid leakage from the gland and the flange face • Loosened bolts • Valve and actuator damages
Operating status	Semiannual	<ul style="list-style-type: none"> • Unstable open/close operation • Abnormal noise and vibration
Routine inspection	Any time	<ul style="list-style-type: none"> • Fluid leakage to the outside • Abnormal noise and vibration • Unstable open/close operation • Valve hunting

Table 2. Troubleshooting

Problem	Part to check	Action
Fluid leaks from the flange face.	Loosened flange bolts Gasket on the flange face Misaligned piping	Tighten the flange bolts. Replace the gasket. Redo piping.
Fluid leaks from the gland part.	—	Consult with our sales personnel.
Fluid leaks from the bonnet.	Loosened bolts	Tighten the bolts.
Valve does not operate smoothly / valve stops halfway / valve does not operate at all.	Conditions of the power applied and of the input signal applied Loosened terminals Wiring condition / disconnected wires	Check the power supply and the controller connected to. Tighten the terminals. Check the wiring.
Fluid leaks to the outside of the valve when the ACTIVAL is in fully closed position.	Actuator pointer not pointing to fully closed position	Fully close the ACTIVAL.
The valve vibrates or produces an abnormal noise.	Primary pressure condition Differential pressure condition	Adjust the mounting position and change the installation location.
The auxiliary switch does not operate.	Auxiliary switch (cam switch) condition Loosened terminals Wiring condition / disconnected wires	Redo the cam switch setting. Tighten the terminals. Check the wiring.
The auxiliary potentiometer does not operate.	Condition of resistance Loosened terminals Wiring condition / disconnected wires	Check the resistance value (1 kΩ). Tighten the terminals. Check the wiring.
Valve hunting occurs.	Secondary pressure condition Differential pressure condition Control stability	Adjust the mounting position and change the installation location. Correct the control parameter setting of controller.
Input signal disagrees with the feedback output signal.	To completely shut off the valve, valve open and close (0-100% position) operation is controlled by 10-90 % range of actuator voltage/current input signal. Input signal therefore disagrees with the feedback signal, and this is not an error.	

ACTIVAL is a trademark of Azbil Corporation in Japan or in other countries.

azbil

Specifications are subject to change without notice.

Azbil Corporation

Building Systems Company

1-12-2 Kawana, Fujisawa, Kanagawa
251-8522 JAPAN

<http://www.azbil.com/>